

# Stormwater Report

**Project Name:** Merlino Residence  
**Project Address:** 4225 89<sup>th</sup> Ave SE, Mercer Island  
**Parcel No.:** 445730-0255  
**Applicant:** John Merlino  
**Submittal Date:** November 13, 2020

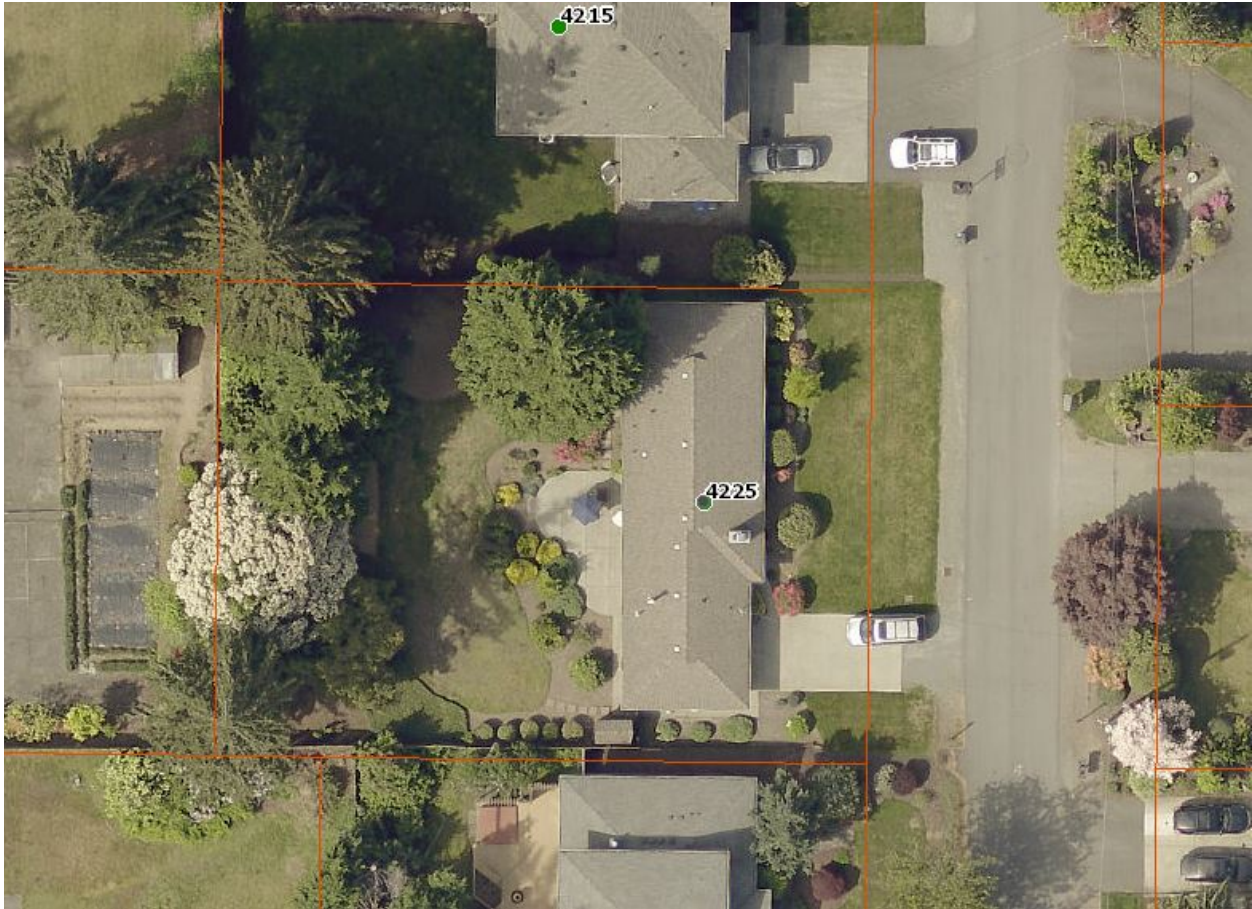

*I hereby state that this Stormwater Report and Construction Stormwater Pollution Prevention Plan for Merlino Residence has been prepared by me or under my supervision and meets the standard of care and expertise which is usual and customary in this community for professional engineers. I understand that the City of Mercer Island does not and will not assume liability for the sufficiency, suitability, or performance of drainage facilities or Construction SWPPP BMPs prepared by me.*

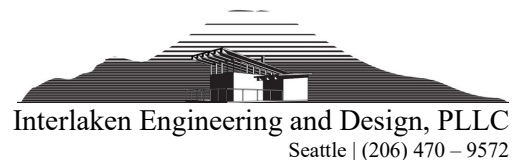

### **Project Overview**

The project site is located in Mercer Island on a 0.30-acre lot zoned R-9.6. The lot presently contains a single-family residence, shed, and landscaping. The owner proposes to remove the existing structures and build a new single-family residence. The existing driveway will be removed as a part of this project and access will be provided by a new driveway entering the site from 89<sup>th</sup> Ave SE.



**Figure 1: Locus map with project site highlighted.**

### **Existing Conditions**

The project site is located in Mercer Island on a 0.30-acre lot (Parcel No. 445730-0255) on the western side of 89<sup>th</sup> Ave. SE between SE 42<sup>nd</sup> St. and SE 43<sup>rd</sup> St.

The lot presently contains a single-family residence, a shed, and landscaping. The lot slopes gently from the southeastern corner to the northwest. Under existing conditions there is approximately 3,038 sf of impervious surface on the project site. The lot loses approximately 5' of elevation between the southeastern and northwestern corners of the lot.

### **Proposed Conditions**

The owner proposes to construct a new single-family residence. Access will be provided by a new driveway extending west into the lot from 89<sup>th</sup> Ave SE. The proposed project will result in a total of 5,389 sf of new plus replaced hard surface. The proposed new residence will have a roof area of 4,589 sf, the proposed driveway will contribute a hard surface area of 630 sf, the new walkway will provide 85 sf of hard surface area, and the proposed rear patio that extends beyond the roof eaves will contribute 80 sf. A total area of approximately 8,500 sf will be disturbed with this project, resulting in approximately 3,111 sf of disturbed turf area- this will be amended with compost as outlined below.

**Jurisdictional Requirements**

The proposed project is subject to All Minimum Requirements (hereafter MR #1-9) as outlined below with a brief summary of how they will be met. Stormwater Management Manual for Western Washington Figure 2.4.1 – Flow Chart for Determining Requirements for New Development is included in the Appendix.

<b>MR #1: Preparation of Storm Water Site Plans</b>	Stormwater Site Plans are included with this submittal.
<b>MR #2: Construction Stormwater Pollution Prevention Plan (CSWPPP)</b>	A Construction Stormwater Pollution Prevention Plan has been prepared as part of the Stormwater Site Plan packet that is included with this submittal. The CSWPPP required elements are addressed below.
<b>MR #3: Source Control of Pollution</b>	A Temporary Erosion and Sediment Control Plan is included with this submittal. BMP S411 will be used for Landscaping and Lawn/ Vegetation Management operational practices.
<b>MR #4: Preservation of Natural Drainage Systems and Outfalls</b>	The proposed development will not alter the existing drainage pattern for this lot. The existing catch basin in the 89 <sup>th</sup> Ave SE frontage will be protected during construction.
<b>MR #5: On-site Stormwater Management</b>	Full Dispersion BMPs are not recommended because the site cannot meet setback and native vegetation requirements.  Infiltration BMPs are proposed. Roof runoff will be routed to an infiltration drywell in the northwestern corner of the project site. Non-roof surfaces will be mitigated with permeable pavement.
<b>MR #6: Runoff Treatment</b>	The proposed project does not exceed the 5,000 sf PGHS threshold. The water quality standard does not apply.
<b>MR #7: Flow Control</b>	All runoff will be infiltrated on-site through stormwater management BMPs. Flow Control facilities will not be required for this project.
<b>MR #8: Wetlands Protection</b>	There are no wetlands in the vicinity of the proposed project.
<b>MR #9: Operations and Maintenance</b>	Operations and Maintenance instructions for BMPs requiring maintenance have been included in the Appendix.

**Infiltration Feasibility Assessment**

A Geotechnical Engineering Report was prepared by Earth Solutions NW. The project site was found to be underlain by medium dense to dense glacial till and recessional outwash deposits. Test pits were consistent with recessional outwash, generally showing silty sand and silty gravel. In-situ testing was completed in accordance with the PIT procedure yielding a measured rate of 28 inches per hour and a corrected long-term infiltration rate of 6.3 inches per hour. The full Geotechnical Engineering Report has been included in the Appendix.

### **Offsite Runoff**

There is an existing catch basin in the 89<sup>th</sup> Ave. SE frontage that collects roadway runoff in the vicinity of the project site. Runoff from the existing residence and hard surfaces generally disperse and infiltrate across the site to the northwest. Flows that are not dispersed or infiltrated flow overland through adjoining residential lots to the northwest before entering the municipal drainage system near the intersection of SE 42<sup>nd</sup> St. and 88<sup>th</sup> Ave SE.

### **Hydrology/ Hydraulic Analysis**

Formal hydrology and pipe flow hydraulic calculations were not completed for the proposed project. Assuming a Manning's Roughness Coefficient of  $n=0.12$  a 4" PVC pipe at a 1.0% slope will provide capacity for approximately 0.207 cfs. The Rational Method would yield a maximum flow for the 100 year storm from the entire roof area of approximately 0.2 cfs. The proposed 4" pipes provide adequate capacity.

### **MR #5 On-Site Stormwater Management – List Approach**

#### **Lawn and Landscaped Areas:**

Soil preservation and amendment BMP is required on all lawn and landscaped areas in accordance with SWMMWW BMP T5.13 in Chapter 5 of Volume V. Compost-amended soil is required. An area of approximately 3,111 sf of turf shall be amended with compost in accordance with the Pre-Approved Amendment Method. At an application rate of 5.4 cy of compost per 1,000 sf, approximate 17 cy of compost will be required.

#### **Roofs:**

**Full Dispersion** is **infeasible** for the project because the site is not large enough to allow for preservation of adequate vegetation and has been developed as a single-family residence since at least 1958.

**Downspout Full Infiltration** is **feasible** and **proposed** for the project. All roof runoff will be collected by gutters and downspouts and routed to a drywell near the northwestern corner of the proposed residence but beyond the required 10' setback from structures. The drywell has been sized in accordance with SWMMWW BMP T5.10A which requires a volume of gravel equal to or greater than 60 cubic feet per 1000 square feet of impervious surface served. The drywell will serve a roof area of 4,589 sf, which requires a gravel volume of 276 cf. A 5' deep drywell with a diameter of 8.5' is proposed which provides a gravel volume of 284 cf.

#### **Other Hard Surfaces (ie Driveway):**

**Full Dispersion** is **infeasible** for the project because the site is not large enough to allow for preservation of adequate vegetation.

**Permeable Pavement** is **feasible** and **proposed** for the proposed driveway, walkway, and feasible portions of the proposed rear patio. At the designer's and contractor's discretion these areas will be paved with porous hot or warm-mix asphalt pavement or pervious Portland cement concrete in accordance with SWMMWW BMP T5.15 or the City of Mercer Island Permeable Paver Block Design guidelines.

### **Construction Stormwater Pollution Prevention Plan Required Elements**

#### 1) Preserve Vegetation/ Mark Clearing Limits

The perimeter of the area to be cleared shall be marked prior to clearing operations with visible flagging, orange plastic barrier fencing and/ or orange silt fencing as shown on Sheet C1 TESC/ Demo/ SWPPP. Vehicles will only be allowed in the areas to be graded, so no compaction of the undeveloped areas will



Interlaken Engineering and Design, PLLC

occur. Natural Vegetation will be preserved to the maximum extent feasible in accordance with BMP C101. The limits of work will be established with a high visibility fence in accordance with BMP C103.

#### 2) Establish Construction Access

The existing site driveway is being removed as a part of the proposed project. In order to preserve the infiltrative capacity of the proposed new driveway the existing driveway will be used for construction access.

#### 3) Control Flow Rates

Flow rates will be controlled by using SWPPP Element 4 sediment controls and BMP T5.13 Post-Construction Soil Quality and Depth. Due to the small scale of the project and overland flow distance to downstream conveyance systems, it is anticipated that Silt Fences installed in accordance with BMP C233 will provide adequate flow dissipation.

#### 4) Install Sediment Controls

Sediment control BMPs shall be placed at the locations shown on the TESC/ Demo/ SWPPP plan. Silt Fence will be installed around the proposed work area in parallel with the proposed limit of work fence in accordance with BMP C233.

#### 5) Stabilize Soils

Exposed soils shall be worked during the week until they have been stabilized. Soil stockpiles will be located within the disturbed area shown on the TESC/ Demo/ SWPPP plan. Soil excavated for the foundation will be backfilled against the foundation and graded to drain away from the building. No soils shall remain exposed and unworked for more than 7 days from May 1 to September 30 or more than 2 days from October 1 to April 30. Once the disturbed landscape areas are graded, the grass areas will be amended using BMP T5.13 Post-Construction Soil Quality and Depth. All stockpiles will be covered with plastic or burlap if left unworked. Temporary seeding and mulching will be performed in accordance with BMP C120 and BMP C121 respectively.

#### 6) Protect Slopes

This element does not apply to this project because no cut slopes over 4 feet high or slopes steeper than 2 feet horizontal to 1 foot vertical, and no fill slopes over 4 feet high will exceed 3 feet horizontal to 1 foot vertical. Therefore, there is no requirement for additional engineered slope protections.

#### 7) Protect Drain Inlets

Catch basins on the site or immediately off site in the right-of-way are shown on the TESC/ Demo/ SWPPP plan. Storm drain inlet protection shall be installed. There are no existing drain inlets immediately downstream of the project site. While minimum runoff from the project site flows to the existing catch basin in the 89ths Ave SE frontage, Storm Drain Inlet Protection for that structure will be provided in accordance with BMP C220.

#### 8) Stabilize Channels and Outlets

Due to the flat topography of the site, it is not anticipated that swales or wattles will be required.

#### 9) Control Pollutants

Any and all pollutants, chemicals, liquid products and other materials that have the potential to pose a threat to human health or the environment will be covered, contained, and protected from vandalism. All such products shall be kept under cover in a secure location on-site. Concrete handling shall follow BMP C151. Material Delivery, Storage, and Containment shall follow BMP C153.

10) Control De-Watering

De-Watering of the site is not anticipated.

11) Maintain BMPs

Best Management Practices or BMPs shall be inspected and maintained during construction and removed within 30 days after the City Inspector or Engineer determines that the site is stabilized, provided that they may be removed when they are no longer needed.

12) Manage the Project

The SWPPP will be implemented at all times. The applicable erosion control BMPs will be implemented in the following sequent:

- 1) Mark Clearing Limits
- 2) Designate existing driveway as construction entrance.
- 3) Install protection for existing drainage systems and permanent drain inlets.
- 4) Establish staging areas for storage and handling polluted materials and BMPs.
- 5) Install sediment control BMPs.
- 6) Grade and install stabilization measures for disturbed areas.
- 7) Maintain BMPs until final site stabilization at which time they may be removed.

13) Protect Low Impact Development BMPs

High visibility fence will be used to delineate proposed new driveway and proposed drywell and protect them from compaction during construction. This fencing will remain in place until the installation of the driveway and drywell.

**Appendix**

- 1) SWMMWW Figure 2.4.1 – Flow Chart for Determining Minimum Requirements for New Development
- 2) Geotechnical Engineering Study Proposed Single-Family Residence 4225 89<sup>th</sup> Avenue SE prepared by Earth Solutions NW, dated November 2, 2020.
- 3) CSWPPP BMPs

**Submitted Under Separate Cover**

- 4) Stormwater Site Plans including TESC/ CSWPP Plan

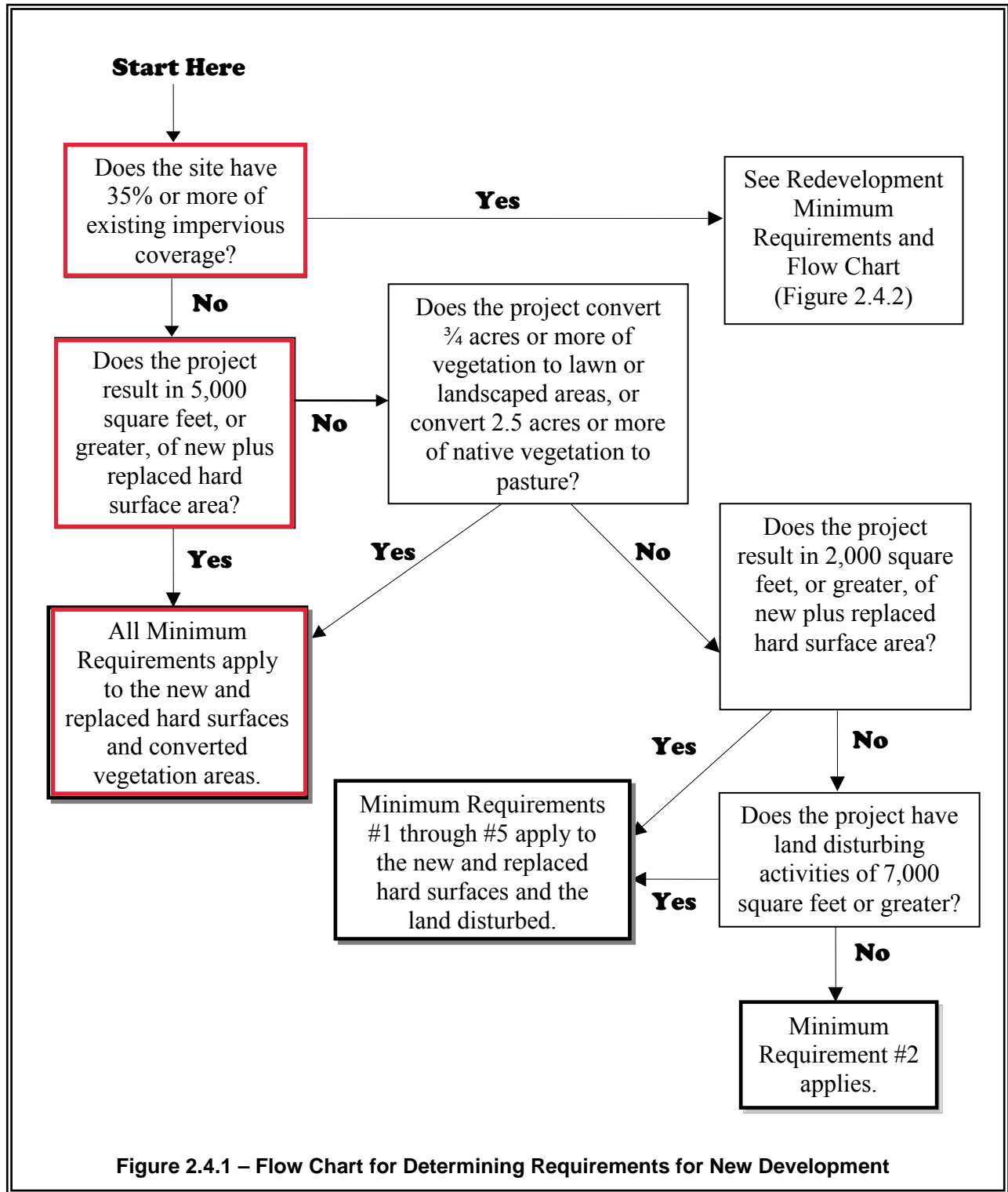



Geotechnical Engineering  
Construction Observation/Testing  
Environmental Services



**GEOTECHNICAL ENGINEERING STUDY  
PROPOSED SINGLE-FAMILY RESIDENCE  
4225 – 89<sup>TH</sup> AVENUE SOUTHEAST  
MERCER ISLAND, WASHINGTON**

**ES-7526**

15365 N.E. 90th Street, Suite 100 Redmond, WA 98052  
(425) 449-4704 Fax (425) 449-4711  
[www.earthsolutionsnw.com](http://www.earthsolutionsnw.com)



**PREPARED FOR**

**MR. JOHN MERLINO  
c/o CENTURY COMMUNITIES**

**November 2, 2020**



---

**Adam Z. Shier, L.G.  
Project Geologist**



---

**Raymond A. Coglas, P.E.  
Principal Engineer**

**GEOTECHNICAL ENGINEERING STUDY  
PROPOSED SINGLE-FAMILY RESIDENCE  
4225 – 89<sup>TH</sup> AVENUE SOUTHEAST  
MERCER ISLAND, WASHINGTON**

**ES-7526**

**Earth Solutions NW, LLC  
15365 Northeast 90<sup>th</sup> Street, Suite 100  
Redmond, Washington 98052  
Phone: 425-449-4704 | Fax: 425-449-4711  
[www.earthsolutionsnw.com](http://www.earthsolutionsnw.com)**

# Important Information about This

# Geotechnical-Engineering Report

Subsurface problems are a principal cause of construction delays, cost overruns, claims, and disputes.

While you cannot eliminate all such risks, you can manage them. The following information is provided to help.

**The Geoprofessional Business Association (GBA) has prepared this advisory to help you – assumedly a client representative – interpret and apply this geotechnical-engineering report as effectively as possible. In that way, you can benefit from a lowered exposure to problems associated with subsurface conditions at project sites and development of them that, for decades, have been a principal cause of construction delays, cost overruns, claims, and disputes. If you have questions or want more information about any of the issues discussed herein, contact your GBA-member geotechnical engineer. Active engagement in GBA exposes geotechnical engineers to a wide array of risk-confrontation techniques that can be of genuine benefit for everyone involved with a construction project.**

## Understand the Geotechnical-Engineering Services Provided for this Report

Geotechnical-engineering services typically include the planning, collection, interpretation, and analysis of exploratory data from widely spaced borings and/or test pits. Field data are combined with results from laboratory tests of soil and rock samples obtained from field exploration (if applicable), observations made during site reconnaissance, and historical information to form one or more models of the expected subsurface conditions beneath the site. Local geology and alterations of the site surface and subsurface by previous and proposed construction are also important considerations. Geotechnical engineers apply their engineering training, experience, and judgment to adapt the requirements of the prospective project to the subsurface model(s). Estimates are made of the subsurface conditions that will likely be exposed during construction as well as the expected performance of foundations and other structures being planned and/or affected by construction activities.

The culmination of these geotechnical-engineering services is typically a geotechnical-engineering report providing the data obtained, a discussion of the subsurface model(s), the engineering and geologic engineering assessments and analyses made, and the recommendations developed to satisfy the given requirements of the project. These reports may be titled investigations, explorations, studies, assessments, or evaluations. Regardless of the title used, the geotechnical-engineering report is an engineering interpretation of the subsurface conditions within the context of the project and does not represent a close examination, systematic inquiry, or thorough investigation of all site and subsurface conditions.

## Geotechnical-Engineering Services are Performed for Specific Purposes, Persons, and Projects, and At Specific Times

Geotechnical engineers structure their services to meet the specific needs, goals, and risk management preferences of their clients. A geotechnical-engineering study conducted for a given civil engineer

will not likely meet the needs of a civil-works constructor or even a different civil engineer. Because each geotechnical-engineering study is unique, each geotechnical-engineering report is unique, prepared *solely* for the client.

Likewise, geotechnical-engineering services are performed for a specific project and purpose. For example, it is unlikely that a geotechnical-engineering study for a refrigerated warehouse will be the same as one prepared for a parking garage; and a few borings drilled during a preliminary study to evaluate site feasibility will not be adequate to develop geotechnical design recommendations for the project.

Do not rely on this report if your geotechnical engineer prepared it:

- for a different client;
- for a different project or purpose;
- for a different site (that may or may not include all or a portion of the original site); or
- before important events occurred at the site or adjacent to it; e.g., man-made events like construction or environmental remediation, or natural events like floods, droughts, earthquakes, or groundwater fluctuations.

Note, too, the reliability of a geotechnical-engineering report can be affected by the passage of time, because of factors like changed subsurface conditions; new or modified codes, standards, or regulations; or new techniques or tools. *If you are the least bit uncertain* about the continued reliability of this report, contact your geotechnical engineer before applying the recommendations in it. A minor amount of additional testing or analysis after the passage of time – if any is required at all – could prevent major problems.

## Read this Report in Full

Costly problems have occurred because those relying on a geotechnical-engineering report did not read the report in its entirety. Do not rely on an executive summary. Do not read selective elements only. *Read and refer to the report in full.*

## You Need to Inform Your Geotechnical Engineer About Change

Your geotechnical engineer considered unique, project-specific factors when developing the scope of study behind this report and developing the confirmation-dependent recommendations the report conveys. Typical changes that could erode the reliability of this report include those that affect:

- the site's size or shape;
- the elevation, configuration, location, orientation, function or weight of the proposed structure and the desired performance criteria;
- the composition of the design team; or
- project ownership.

As a general rule, *always* inform your geotechnical engineer of project or site changes – even minor ones – and request an assessment of their impact. *The geotechnical engineer who prepared this report cannot accept*

responsibility or liability for problems that arise because the geotechnical engineer was not informed about developments the engineer otherwise would have considered.

### Most of the “Findings” Related in This Report Are Professional Opinions

Before construction begins, geotechnical engineers explore a site’s subsurface using various sampling and testing procedures. *Geotechnical engineers can observe actual subsurface conditions only at those specific locations where sampling and testing is performed.* The data derived from that sampling and testing were reviewed by your geotechnical engineer, who then applied professional judgement to form opinions about subsurface conditions throughout the site. Actual sitewide-subsurface conditions may differ – maybe significantly – from those indicated in this report. Confront that risk by retaining your geotechnical engineer to serve on the design team through project completion to obtain informed guidance quickly, whenever needed.

### This Report’s Recommendations Are Confirmation-Dependent

The recommendations included in this report – including any options or alternatives – are confirmation-dependent. In other words, they are not final, because the geotechnical engineer who developed them relied heavily on judgement and opinion to do so. Your geotechnical engineer can finalize the recommendations *only after observing actual subsurface conditions* exposed during construction. If through observation your geotechnical engineer confirms that the conditions assumed to exist actually do exist, the recommendations can be relied upon, assuming no other changes have occurred. *The geotechnical engineer who prepared this report cannot assume responsibility or liability for confirmation-dependent recommendations if you fail to retain that engineer to perform construction observation.*

### This Report Could Be Misinterpreted

Other design professionals’ misinterpretation of geotechnical-engineering reports has resulted in costly problems. Confront that risk by having your geotechnical engineer serve as a continuing member of the design team, to:

- confer with other design-team members;
- help develop specifications;
- review pertinent elements of other design professionals’ plans and specifications; and
- be available whenever geotechnical-engineering guidance is needed.

You should also confront the risk of constructors misinterpreting this report. Do so by retaining your geotechnical engineer to participate in prebid and preconstruction conferences and to perform construction-phase observations.

### Give Constructors a Complete Report and Guidance

Some owners and design professionals mistakenly believe they can shift unanticipated-subsurface-conditions liability to constructors by limiting the information they provide for bid preparation. To help prevent the costly, contentious problems this practice has caused, include the complete geotechnical-engineering report, along with any attachments or appendices, with your contract documents, *but be certain to note*

*conspicuously that you’ve included the material for information purposes only.* To avoid misunderstanding, you may also want to note that “informational purposes” means constructors have no right to rely on the interpretations, opinions, conclusions, or recommendations in the report. Be certain that constructors know they may learn about specific project requirements, including options selected from the report, *only* from the design drawings and specifications. Remind constructors that they may perform their own studies if they want to, and *be sure to allow enough time* to permit them to do so. Only then might you be in a position to give constructors the information available to you, while requiring them to at least share some of the financial responsibilities stemming from unanticipated conditions. Conducting prebid and preconstruction conferences can also be valuable in this respect.

### Read Responsibility Provisions Closely

Some client representatives, design professionals, and constructors do not realize that geotechnical engineering is far less exact than other engineering disciplines. This happens in part because soil and rock on project sites are typically heterogeneous and not manufactured materials with well-defined engineering properties like steel and concrete. That lack of understanding has nurtured unrealistic expectations that have resulted in disappointments, delays, cost overruns, claims, and disputes. To confront that risk, geotechnical engineers commonly include explanatory provisions in their reports. Sometimes labeled “limitations,” many of these provisions indicate where geotechnical engineers’ responsibilities begin and end, to help others recognize their own responsibilities and risks. *Read these provisions closely.* Ask questions. Your geotechnical engineer should respond fully and frankly.

### Geoenvironmental Concerns Are Not Covered

The personnel, equipment, and techniques used to perform an environmental study – e.g., a “phase-one” or “phase-two” environmental site assessment – differ significantly from those used to perform a geotechnical-engineering study. For that reason, a geotechnical-engineering report does not usually provide environmental findings, conclusions, or recommendations; e.g., about the likelihood of encountering underground storage tanks or regulated contaminants. *Unanticipated subsurface environmental problems have led to project failures.* If you have not obtained your own environmental information about the project site, ask your geotechnical consultant for a recommendation on how to find environmental risk-management guidance.

### Obtain Professional Assistance to Deal with Moisture Infiltration and Mold

While your geotechnical engineer may have addressed groundwater, water infiltration, or similar issues in this report, the engineer’s services were not designed, conducted, or intended to prevent migration of moisture – including water vapor – from the soil through building slabs and walls and into the building interior, where it can cause mold growth and material-performance deficiencies. Accordingly, *proper implementation of the geotechnical engineer’s recommendations will not of itself be sufficient to prevent moisture infiltration.* **Confront the risk of moisture infiltration** by including building-envelope or mold specialists on the design team. **Geotechnical engineers are not building-envelope or mold specialists.**



Telephone: 301/565-2733

e-mail: [info@geoprofessional.org](mailto:info@geoprofessional.org) [www.geoprofessional.org](http://www.geoprofessional.org)



November 2, 2020  
ES-7526

## Earth Solutions NW LLC

Geotechnical Engineering, Construction  
Observation/Testing and Environmental Services

Mr. John Merlino  
c/o Century Communities  
16108 Ash Way, Suite 201  
Lynnwood, Washington 98087

Dear Mr. Merlino:

Earth Solutions NW, LLC (ESNW) is pleased to present this report titled "Geotechnical Engineering Study, Proposed Single-Family Residence, 4225 – 89<sup>th</sup> Avenue Southeast, Mercer Island, Washington". Based on the results of our study, the proposed redevelopment is feasible from a geotechnical standpoint.

Based on the conditions observed during our fieldwork, the subject site is underlain primarily by native soil consisting of medium dense to dense glacial till and recessional outwash deposits. The proposed structure can be supported on conventional spread and continuous foundations bearing on undisturbed, competent native soil, recompacted native soil, or new structural fill. We anticipate competent native soil suitable for support of foundations to be encountered beginning at depths of about two to three feet below existing grades across the majority of the site.

This report provides recommendations for foundation subgrade preparation, foundation and retaining wall design parameters, drainage, infiltration feasibility, the suitability of on-site soils for use as structural fill, and other pertinent geotechnical recommendations. The opportunity to be of service to you is appreciated. If you have any questions regarding the content of this geotechnical engineering study, please call.

Sincerely,

**EARTH SOLUTIONS NW, LLC**

Adam Z. Shier, L.G.  
Project Geologist

## Table of Contents

ES-7526

	<u>PAGE</u>
<b><u>INTRODUCTION</u></b> .....	1
<u>General</u> .....	1
<u>Project Description</u> .....	2
<b><u>SITE CONDITIONS</u></b> .....	2
<u>Surface</u> .....	2
<u>Subsurface</u> .....	2
Fill .....	2
Native Soil .....	3
Geologic Setting .....	3
Groundwater .....	3
<b><u>GEOLOGICALLY HAZARDOUS AREAS ASSESSMENT</u></b> .....	3
<u>Seismic Hazard</u> .....	3
<u>Statement of Risk</u> .....	4
<b><u>DISCUSSION AND RECOMMENDATIONS</u></b> .....	4
<u>General</u> .....	4
<u>Site Preparation and Earthwork</u> .....	5
Temporary Erosion Control .....	5
In-situ Soils .....	5
Structural Fill .....	6
Excavations and Slopes .....	6
<u>Foundations</u> .....	7
<u>Slab-on-Grade Floors</u> .....	7
<u>Retaining Walls</u> .....	8
<u>Drainage</u> .....	8
Infiltration Evaluation .....	9
<u>Utility Support and Trench Backfill</u> .....	9
<b><u>LIMITATIONS</u></b> .....	10
<u>Additional Services</u> .....	10

## **Table of Contents**

**Cont'd**

**ES-7526**

### **GRAPHICS**

<b>Plate 1</b>	<b>Vicinity Map</b>
<b>Plate 2</b>	<b>Test Pit Location Plan</b>
<b>Plate 3</b>	<b>Retaining Wall Drainage Detail</b>
<b>Plate 4</b>	<b>Footing Drain Detail</b>

### **APPENDICES**

<b>Appendix A</b>	<b>Subsurface Exploration Test Pit Logs</b>
<b>Appendix B</b>	<b>Laboratory Test Results</b>

**GEOTECHNICAL ENGINEERING STUDY  
PROPOSED SINGLE-FAMILY RESIDENCE  
4225 – 89<sup>TH</sup> AVENUE SOUTHEAST  
MERCER ISLAND, WASHINGTON**

**ES-7526**

**INTRODUCTION**

**General**

This geotechnical engineering study (study) was prepared for the proposed single-family residence to be constructed at 4225 – 89<sup>th</sup> Avenue Southeast, in Mercer Island, Washington. To prepare this study, we completed the following:

- Subsurface exploration for purposes of characterizing soil and groundwater conditions;
- Laboratory testing of soil samples collected at the test pit locations;
- In-situ infiltration testing;
- Engineering analyses and recommendations for the proposed development, and;
- Preparation of this report.

The following documents and resources were reviewed as part of our report preparation:

- Site Plan, prepared by BROBST Design Works., dated July 16, 2020;
- Geologic Map of Mercer Island, Washington, by Kathy G. Troost and Aaron P. Wisher, October 2006;
- Stormwater Management Manual for Western Washington, prepared by the Washington State Department of Ecology, amended December 2014;
- Mercer Island Seismic Hazard Assessment, Landslide Hazard Assessment, and Erosion Hazard Assessment maps, by Kathy G. Troost and Aaron P. Wisher, April 2009;
- Low Impact Development Infiltration Feasibility on Mercer Island, prepared by Herrera Environmental Consultants, Inc.;
- Liquefaction Susceptibility Map of King County, Washington, endorsed by the King County Flood Control District, May 2010;
- Mercer Island City Code (MICC), and;
- Online Web Soil Survey (WSS) resource, provided by the United States Department of Agriculture, Natural Resources Conservation Service.

## **Project Description**

Based on the referenced plans, the site will be redeveloped with a new single-family residence and associated infrastructure improvements. We anticipate the new building footprint will be in proximity to the footprint area of the existing residence. At the time of report submission, specific grading and building load values were not available for review. However, due to the relatively flat topography throughout the site, we anticipate minimal site grading will be necessary. We anticipate the proposed residential structure will consist of relatively lightly loaded wood framing supported on conventional foundations. Based on our experience with similar developments, we estimate wall loads of about 1 to 2 kips per linear foot and slab-on-grade loading of about 150 pounds per square foot (psf) will be incorporated into final designs. At this time, we understand infiltration will be pursued to the extent practicable for purposes of stormwater management.

If the above design assumptions are incorrect or change, ESNW should be contacted to review the recommendations provided in this report. ESNW should review final designs to verify the geotechnical recommendations provided in this report have been incorporated into the plans.

## **SITE CONDITIONS**

### **Surface**

The subject site is located on the west side of 89<sup>th</sup> Avenue Southeast approximately 150 feet south of the intersection with Southeast 42<sup>nd</sup> Street, in Mercer Island, Washington, as illustrated on the Vicinity Map (Plate 1). The property is comprised of one tax parcel (King County Parcel No. 445730-0255) totaling approximately 0.30 acres of land area.

The site is surrounded to the north, south, and west by single-family residences, and to the east by 89<sup>th</sup> Avenue Southeast. Existing topography descends toward the northwest, with approximately five feet of elevation change across the site.

### **Subsurface**

An ESNW representative observed, logged, and sampled two test pits, excavated at accessible locations within the property boundaries, on October 8, 2020, using a trackhoe and operator contracted by ESNW. The test pits were completed to assess and classify site soils as well as to characterize groundwater conditions within accessible areas of the site. The approximate locations of the test pits are depicted on Plate 2 (Test Pit Location Plan). Please refer to the test pit logs provided in Appendix A for a more detailed description of subsurface conditions. Representative soil samples collected at the test pit locations were analyzed in accordance with both Unified Soil Classification System (USCS) and USDA methods and procedures.

### **Fill**

Fill was encountered at both test pit locations extending to depths of one-half to one-foot below existing ground surface (bgs). The fill was characterized as silty sand (USCS SM), consistent with reworked native soil. A relic topsoil layer was encountered below the fill at both test pit locations.



## **Native Soil**

Underlying the limited fill and relic topsoil layer, native soils consisted of poorly graded sand with and without silt (USCS: SP-SM and SP, respectively) at TP-1 generally consistent with the typical makeup of recessional outwash. Silty sand and silty gravel (USCS: SM and GM, respectively) was observed at TP-2 generally consistent with the typical makeup of Vashon till. The native soil was generally observed to be in a medium dense condition starting at about two to three feet bgs.

## **Geologic Setting**

The referenced geologic map resource identifies Vashon till deposits (Qvt) as the primary native soil unit underlying the subject site, with Vashon recessional outwash deposits (Qvr) mapped immediately north of the subject site. As described on the geologic map resource, Vashon till is typically a compact diamict of subrounded to well-rounded clasts which were glacially transported and deposited. The diamict is largely composed of sand, silt, gravel, pebbles, and cobbles. Recessional outwash consists of well-drained, stratified outwash sand and gravel deposited by the receding glacier.

The referenced WSS resource identifies Arents, Alderwood material (Map Unit Symbol: AmC) as the primary soil unit underlying the subject development area. The Arents-Alderwood series was formed in glacial till plains and is representative of Alderwood soils that have been disturbed by urban development but retain many features of undisturbed Alderwood soils. Based on our field observations, native soils on the subject site are generally consistent with the Vashon till geologic setting with recessional outwash near the northwest corner of the site, as outlined in this section.

## **Groundwater**

During our subsurface exploration completed on October 8, 2020, groundwater seepage was not encountered at the test pit locations. It is noted groundwater seepage rates and elevations fluctuate depending on many factors, including precipitation duration and intensity, the time of year, and soil conditions. In general, groundwater flow rates are higher during the winter, spring, and early summer months.

## **GEOLOGICALLY HAZARDOUS AREAS ASSESSMENT**

We evaluated the presence of geologic hazards, as defined by the City of Mercer Island (City), within the bounds of the subject property. The subject site has been designated within a seismic hazard area in accordance with the referenced City maps.

## **Seismic Hazard**

The referenced MICC title defines seismic hazard areas as those areas “subject to severe risk of damage as a result of earthquake-induced ground shaking, slope failure, settlement, soil liquefaction, or surface faulting”. According to the referenced seismic hazard map, the property is indicated within a known or suspected seismic hazard area.

The 2015 International Building Code (IBC) recognizes the American Society of Civil Engineers (ASCE) for seismic site class definitions. In accordance with Table 20.3-1 of the ASCE Minimum Design Loads for Buildings and Other Structures manual, Site Class D should be used for design.

The referenced liquefaction susceptibility map indicates the site and surrounding areas maintain very low to low liquefaction susceptibility. Liquefaction is a phenomenon where saturated or loose soils suddenly lose internal strength and behave as a fluid. This behavior is in response to increased pore water pressures resulting from an earthquake or other intense ground shaking. In our opinion, site susceptibility to liquefaction may be considered low. The relatively consistent densities of native soils at depth and the absence of a uniformly established groundwater table were the primary bases for this consideration.

### **Statement of Risk**

Per MICC 19.07.160(B)(3), alterations of seismic hazard areas may occur if the conditions listed in MICC 19.07.160(B)(2) are satisfied and the geotechnical professional provides a statement of risk matching one of the following:

- a. An evaluation of site-specific subsurface conditions demonstrates that the proposed development is not located in a landslide hazard area or seismic hazard area.
- b. The landslide hazard area will be modified, or the development has been designed, so that the risk to the site and adjacent property is eliminated or mitigated, such that the site is determined safe.
- c. Construction practices are proposed for the alteration that would render the development safe as it were not located in a geologically hazardous area and do not adversely impact adjacent properties.
- d. The development is so minor as not to pose a threat to public health, safety, and welfare.

In our opinion, criterion "c" is met. Based on our understanding of the proposed development, it is our opinion that, provided our geotechnical recommendations are incorporated into final designs and maintained throughout construction, the development will be designed so that the risk to both the subject site and adjacent properties is mitigated, and as such, the site will be determined to be safe. ESNW must be contacted to review final submittal plans to ensure our geotechnical recommendations have been adequately incorporated into the plans.

## **DISCUSSION AND RECOMMENDATIONS**

### **General**

Based on the results of our investigation, construction of the proposed single-family residence is feasible from a geotechnical standpoint. The primary geotechnical considerations associated with the proposed development include foundation support, slab-on-grade subgrade support, and the suitability of using on-site soils as structural fill.

In our opinion, the proposed residential structure may be constructed on a conventional continuous and spread footing foundation bearing upon competent native soil, recompacted native soil, or new structural fill. In general, competent native soil suitable for support of the foundations will likely be encountered within the upper two to three feet of existing grades. Where loose or unsuitable soil conditions are exposed at foundation subgrade elevations, compaction of soils to the specifications of structural fill, or overexcavation and replacement with suitable structural fill, will be necessary.

This study has been prepared for the exclusive use of Mr. John Merlino and his representatives. No warranty, expressed or implied, is made. This study has been prepared in a manner consistent with the level of care and skill ordinarily exercised by other members of the profession currently practicing under similar conditions in this area.

### **Site Preparation and Earthwork**

Initial site preparation activities will consist of installing temporary erosion control measures, establishing grading limits, and performing clearing and site stripping (as necessary). Grading for the project will likely be minimal, as we anticipate the new building footprint will be in proximity to the existing residence. Site improvements will also include underground utility installations.

### **Temporary Erosion Control**

Temporary construction entrances and drive lanes, consisting of at least six inches of quarry spalls, should be considered in order to minimize off-site soil tracking and to provide a temporary road surface. Temporary slopes and stockpiles should be covered when not in use. Silt fencing should be installed along the margins of the property. Temporary measures for controlling surface water runoff, such as interceptor trenches, sumps, or interceptor swales, should be installed prior to beginning earthwork activities. When not in use, soil stockpiles should be covered with plastic sheeting or otherwise protected. Additional BMPs, as specified by the project civil engineer and indicated on the plans, should be incorporated into construction activities. Temporary erosion control measures may be modified during construction as site conditions require, as approved by the site erosion control lead.

### **In-situ Soils**

From a geotechnical standpoint, on-site soils expected to be exposed during typical grading are considered moisture sensitive and will degrade rapidly if exposed to wet weather and construction traffic. Compaction of the soil to the levels necessary for use as structural fill will be difficult or impossible during wet weather conditions. Soils encountered during site excavations that are excessively over the optimum moisture content will require aeration or treatment prior to placement and compaction. Conversely, soils that are below the optimum moisture content will require moisture conditioning through the addition of water prior to use as structural fill. An ESNW representative should determine the suitability of in-situ soils for use as structural fill at the time of construction.

Imported soil intended for use as structural fill should consist of a well-graded, granular soil with a moisture content that is at (or slightly above) the optimum level. During wet weather conditions, imported soil intended for use as structural fill should consist of a well-graded, granular soil with a fines content of 5 percent or less (where the fines content is defined as the percent passing the Number 200 sieve, based on the minus three-quarter-inch fraction).

## Structural Fill

Structural fill is defined as compacted soil placed in foundation, slab-on-grade, roadway, permanent slope, retaining wall, and utility trench backfill areas. Structural fill placed and compacted during site grading activities should meet the following specifications and guidelines:

- |                                  |                                |
|----------------------------------|--------------------------------|
| • Structural fill material       | Granular soil*                 |
| • Moisture content               | At or slightly above optimum** |
| • Relative compaction (minimum)  | 90 percent (Modified Proctor)  |
| • Loose lift thickness (maximum) | 12 inches                      |

\* *The existing soil is not suitable for use as structural fill unless the soil is at (or slightly above) the optimum moisture content at the time of placement and compaction and is devoid of deleterious debris and organics.*

\*\* *Soil shall not be placed dry of optimum and should be evaluated by ESNW during construction.*

With respect to underground utility installations and backfill, local jurisdictions may dictate the soil type(s) and compaction requirements. Areas of otherwise unsuitable material and debris should be removed from structural areas and replaced with structural fill.

## Excavations and Slopes

Excavation activities across the site are likely to expose loose fill and/or medium dense native soil within the upper approximately two to three feet bgs, transitioning into dense to very dense glacial till (“hardpan”) with depth along the eastern portion of the subject site. Based on the soil conditions observed at the test pit locations, the following allowable temporary slope inclinations, as a function of horizontal to vertical (H:V) inclination, may be used. The applicable Federal Occupation Safety and Health Administration and Washington Industrial Safety and Health Act soil classifications are also provided:

- |   |                   |
|---|-------------------|
| • Areas exposing groundwater seepage        | 1.5H:1V (Type C)  |
| • Loose native soil; areas of fill          | 1.5H:1V (Type C)  |
| • Medium dense native soil                  | 1H:1V (Type B)    |
| • Dense to very dense “hardpan” native soil | 0.75H:1V (Type A) |

Permanent slopes should be planted with vegetation to enhance stability and to minimize erosion, and should maintain a gradient of 2H:1V or flatter. The presence of perched groundwater may cause localized sloughing of temporary slopes due to excess seepage forces. An ESNW representative should observe temporary and permanent slopes to confirm the slope inclinations are suitable for the exposed soil conditions and to provide additional excavation and slope recommendations, as necessary. If the recommended temporary slope inclinations cannot be achieved, temporary shoring may be necessary to support excavations.

## **Foundations**

The proposed residential structure can be supported on conventional spread and continuous footings bearing on undisturbed competent native soil, recompacted native soil, or new structural fill. We anticipate competent native soils, suitable for support of foundations, will be encountered beginning at depths of about two to three feet bgs across the majority of the site. Where loose or unsuitable soil conditions are observed at foundation subgrade elevations, compaction of the soils to the specifications of structural fill, or overexcavation and replacement with granular structural fill, will be necessary.

Provided the structure will be supported as described above, the following parameters may be used for design of the new foundation:

- Allowable soil bearing capacity 2,500 psf
- Passive earth pressure 300 pcf (equivalent fluid)
- Coefficient of friction 0.40

The passive earth pressure and coefficient of friction values include a safety factor of 1.5. A one-third increase in the allowable soil bearing capacity may be assumed for short-term wind and seismic loading conditions. With structural loading as expected, total settlement in the range of one inch is anticipated, with differential settlement of about one-half inch. The majority of the settlements should occur during construction, as dead loads are applied.

## **Slab-on-Grade Floors**

Slab-on-grade floors for the proposed residential structure should be supported on a well-compacted, firm, and unyielding subgrade. Where feasible, the native soils likely to be exposed at the slab-on-grade subgrade level can be compacted in place to the specifications of structural fill. Unstable or yielding areas of the subgrade should be recompacted or overexcavated and replaced with suitable structural fill (as previously detailed in this report) prior to slab construction.

A capillary break consisting of at least four inches of free-draining crushed rock or gravel should be placed below the slab. The free-draining material should have a fines content of 5 percent or less (percent passing the Number 200 sieve, based on the minus three-quarter-inch fraction). In areas where slab moisture is undesirable, installation of a vapor barrier below the slab should be considered. If a vapor barrier is to be utilized, it should be a material specifically designed for use as a vapor barrier and should be installed in accordance with the specifications of the manufacturer.

## **Retaining Walls**

Retaining walls must be designed to resist earth pressures and applicable surcharge loads. The following parameters may be used for retaining wall design:

- Active earth pressure (unrestrained condition) 35 pcf
- At-rest earth pressure (restrained condition) 55 pcf
- Traffic surcharge (passenger vehicles) 70 psf (rectangular distribution)
- Passive earth pressure 300 pcf
- Coefficient of friction 0.40
- Seismic surcharge 6H psf\*

\* Where H equals the retained height (in feet)

The passive earth pressure and coefficient of friction values include a safety factor of 1.5. Additional surcharge loading from adjacent foundations, sloped backfill, retaining walls, or other loads should be included in the retaining wall design. Drainage should be provided behind retaining walls such that hydrostatic pressures do not develop. If drainage is not provided, hydrostatic pressures should be included in the wall design.

Retaining walls should be backfilled with at least 18 inches of free-draining material or suitable sheet drainage that extends along the height of the wall. The upper one foot of the wall backfill may consist of a less permeable soil, if desired. A perforated drain pipe should be placed along the base of the wall and connected to an approved discharge location. A typical retaining wall drainage detail is provided on Plate 3.

## **Drainage**

The presence of groundwater seepage should be expected in excavations, especially in a perched condition at the contact between weathered and unweathered till. Where zones of groundwater seepage are encountered, temporary measures to control groundwater seepage may be needed. Temporary measures to control groundwater seepage and surface water runoff during construction will likely involve passive elements such as interceptor trenches and sumps.

Surface grades must be designed to direct water away from slopes and buildings. The grade adjacent to buildings should be sloped away from the buildings at a gradient of at least 2 percent for a horizontal distance of four feet (minimum) and ten feet (maximum) as building and property setbacks allow. In our opinion, perimeter footing drains should be installed at or below the invert of the building footings. A typical footing drain detail is provided on Plate 4 of this report.

## Infiltration Evaluation

In-situ testing was completed in accordance with the small-scale Pilot Infiltration Test (PIT) procedure, as outlined in Chapter 3 of Volume III of the referenced 2014 Manual. The testing was completed at TP-1 at a depth of approximately four feet bgs, and at the conclusion of testing, the measured rate was 28.0 inches per hour (in/hr).

Because the infiltration rate obtained from in-situ testing is a short-term rate, correction factors must be applied to determine a long-term design rate. The correction factors outlined below were determined in accordance with Table III-3.3.1 of the 2014 Manual. The correction factors, along with the measured infiltration rate, were incorporated into the following equation:

$$K_{sat\ design} = K_{sat\ initial} \times CF_v \times CF_t \times CF_m$$

- Short-term infiltration rate ( $K_{sat\ initial}$ ) 28.0 in/hr
- Site variability  $CF_v = 0.5$
- Test method  $CF_t = 0.5$
- Degree of influent control  $CF_m = 0.9$
- Long-term infiltration rate ( $K_{sat\ design}$ ) 6.3 in/hr

The long-term infiltration rate is applicable to facilities located in the outwash sand deposits located in proximity to the infiltration test location (such as the footing drain drywell), as verified by ESNW during plan review. Should a revised location be pursued, ESNW should be contacted to perform additional in-situ testing. In any case, ESNW should review the final design for infiltration facilities to confirm applicability of our recommendations.

ESNW should be retained to observe the construction of infiltration facilities on the subject site to confirm soil conditions are as anticipated and perform confirmation infiltration testing at the infiltration design depth and location, if required. Supplementary geotechnical recommendations may be provided at the time of construction, where necessary.

## Utility Support and Trench Backfill

In our opinion, the soils observed at the test pit locations are generally suitable for support of utilities. The native soils are moisture sensitive, and successful use of native soils as structural backfill in utility trench excavations will largely depend on in-situ moisture contents at the time of placement and compaction. Moisture conditioning or cement treatment of the soils may be necessary at some locations prior to use as structural fill. If utility backfill occurs during wet weather, either cement treatment (where allowed by the presiding jurisdiction) of native soils or import of suitable structural fill will be necessary. Utility trench backfill should be placed and compacted to either the specifications of structural fill provided in this report or to the applicable requirements of the presiding jurisdiction.

### **LIMITATIONS**

The recommendations and conclusions provided in this study are professional opinions consistent with the level of care and skill that is typical of other members in the profession currently practicing under similar conditions in this area. A warranty is neither expressed nor implied. Variations in the soil and groundwater conditions observed at the test pit locations may exist and may not become evident until construction. ESNW should reevaluate the conclusions provided in this study if variations are encountered.

### **Additional Services**

ESNW should have an opportunity to review final designs with respect to the geotechnical recommendations provided in this report. ESNW should also be retained to provide testing and consultation services during construction.





Reference:  
King County, Washington  
OpenStreetMap.org

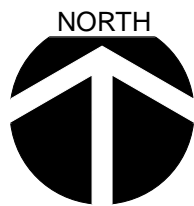

**Earth Solutions NW<sub>LLC</sub>**

Geotechnical Engineering, Construction  
Observation/Testing and Environmental Services

**Vicinity Map  
Merlino SFR  
Mercer Island, Washington**

NOTE: This plate may contain areas of color. ESNW cannot be responsible for any subsequent misinterpretation of the information resulting from black & white reproductions of this plate.

Drwn. MRS	Date 10/21/2020	Proj. No. 7526
Checked AZS	Date Oct. 2020	Plate 1

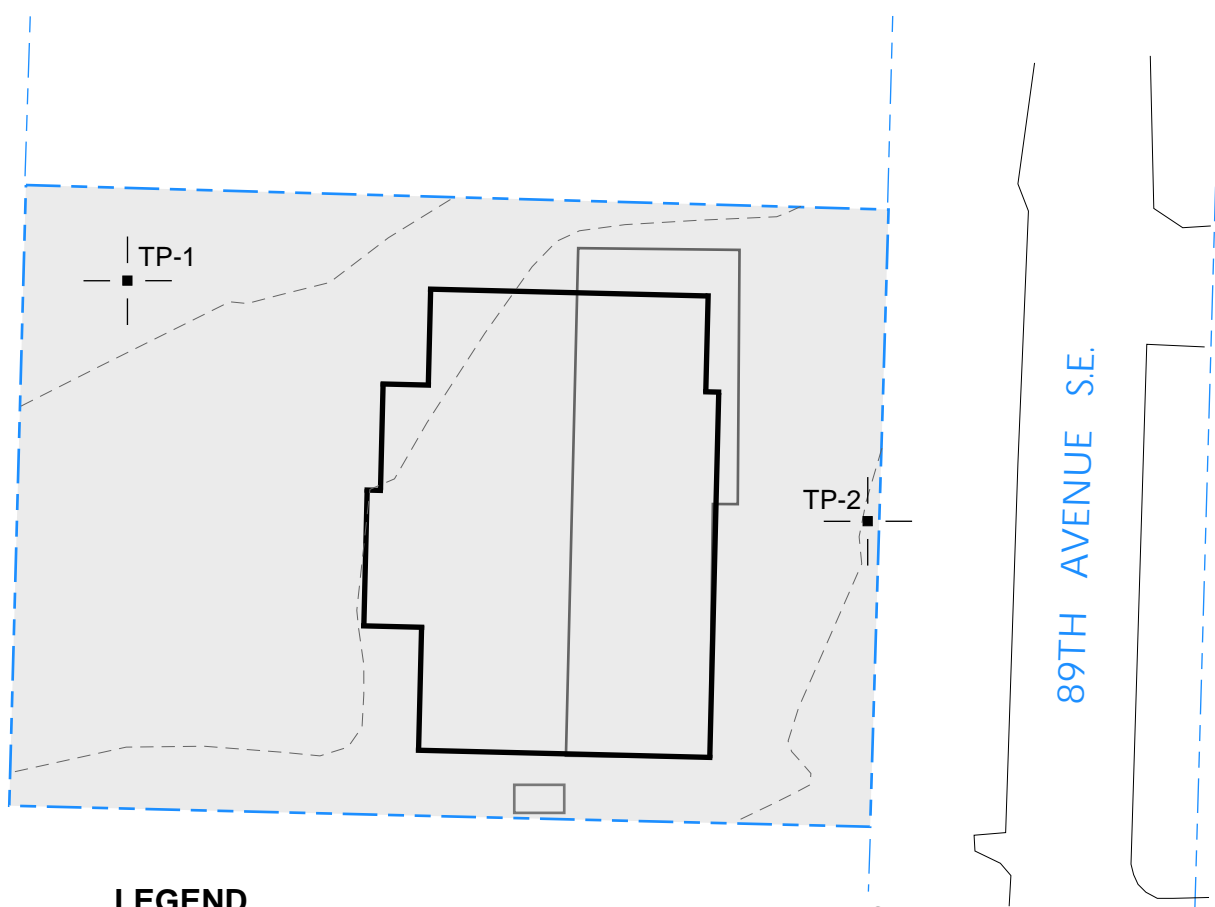

**LEGEND**

TP-1 | — ■ — | Approximate Location of ESNW Test Pit, Proj. No. ES-7526, Oct. 2020

 Subject Site

 Proposed Building

 Existing Building

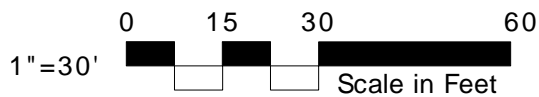

NOTE: The graphics shown on this plate are not intended for design purposes or precise scale measurements, but only to illustrate the approximate test locations relative to the approximate locations of existing and / or proposed site features. The information illustrated is largely based on data provided by the client at the time of our study. ESNW cannot be responsible for subsequent design changes or interpretation of the data by others.

NOTE: This plate may contain areas of color. ESNW cannot be responsible for any subsequent misinterpretation of the information resulting from black & white reproductions of this plate.



**Earth Solutions NW<sub>LLC</sub>**

Geotechnical Engineering, Construction  
Observation/Testing and Environmental Services

**Test Pit Location Plan  
Merlino SFR  
Mercer Island, Washington**

Drwn. MRS	Date 10/21/2020	Proj. No. 7526
Checked AZS	Date Oct. 2020	Plate 2

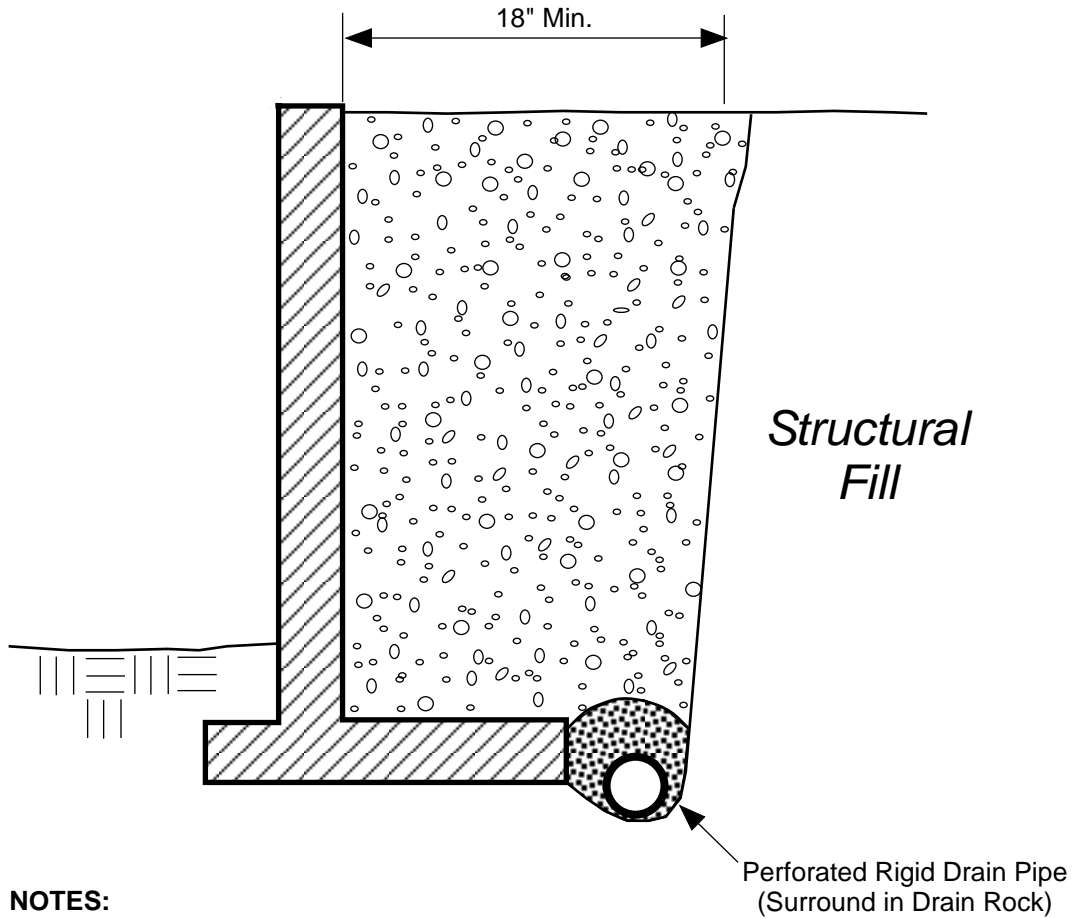

**NOTES:**

- Free-draining Backfill should consist of soil having less than 5 percent fines. Percent passing No. 4 sieve should be 25 to 75 percent.
- Sheet Drain may be feasible in lieu of Free-draining Backfill, per ESNW recommendations.
- Drain Pipe should consist of perforated, rigid PVC Pipe surrounded with 1-inch Drain Rock.

SCHMATIC ONLY - NOT TO SCALE  
NOT A CONSTRUCTION DRAWING

**LEGEND:**

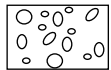

Free-draining Structural Backfill



1-inch Drain Rock

		<b>Earth Solutions NW<sub>LLC</sub></b> Geotechnical Engineering Construction Observation/Testing and Environmental Services	
<b>Retaining Wall Drainage Detail</b> <b>Merlino SFR</b> <b>Mercer Island, Washington</b>			
Drwn. MRS	Date 10/27/2020	Proj. No. 7526	
Checked AZS	Date Oct. 2020	Plate 3	

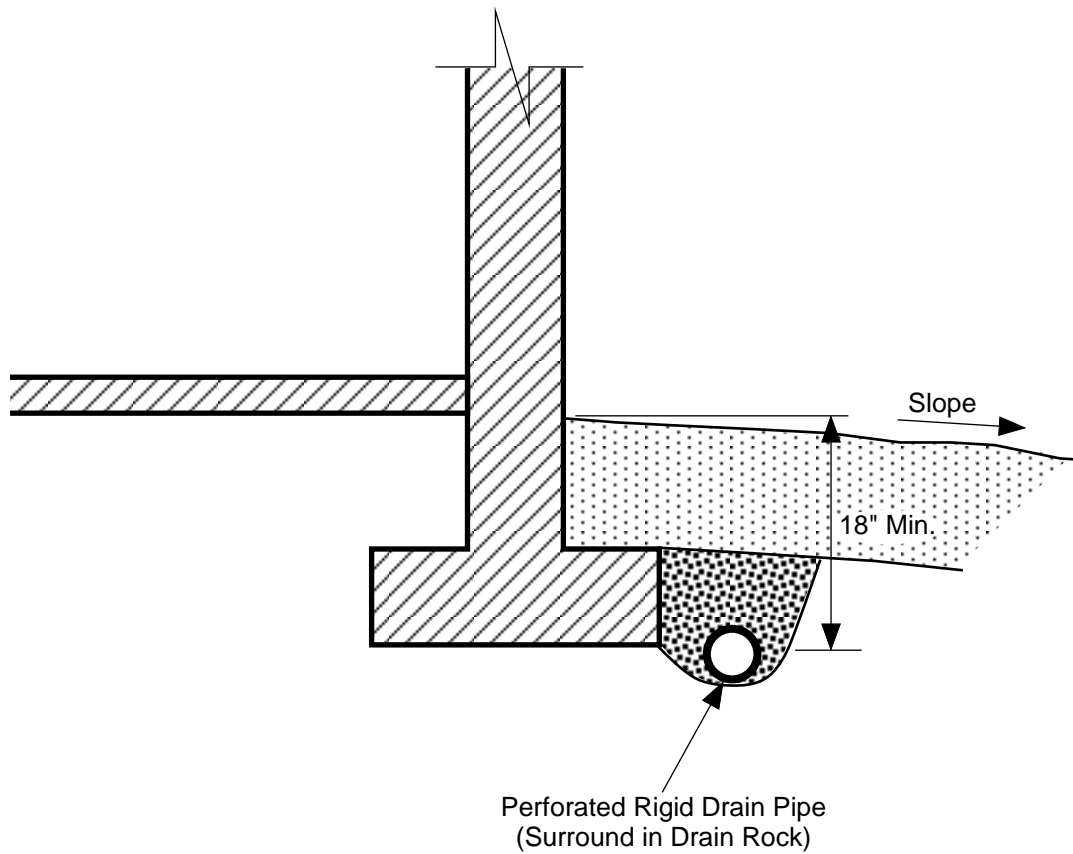



**NOTES:**

- Do NOT tie roof downspouts to Footing Drain.
- Surface Seal to consist of 12" of less permeable, suitable soil. Slope away from building.

SCHEMATIC ONLY - NOT TO SCALE  
NOT A CONSTRUCTION DRAWING

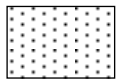
**LEGEND:**

-  Surface Seal: native soil or other low-permeability material.
-  1-inch Drain Rock

	<b>Earth Solutions NW<sub>LLC</sub></b> Geotechnical Engineering, Construction Observation/Testing and Environmental Services	
<b>Footing Drain Detail</b> <b>Merlino SFR</b> <b>Mercer Island, Washington</b>		
Drwn. MRS	Date 10/27/2020	Proj. No. 7526
Checked AZS	Date Oct. 2020	Plate 4

## **Appendix A**

### **Subsurface Exploration Test Pit Logs**







#### **ES-7526**

Subsurface conditions at the subject site were explored on October 8, 2020 by excavating two test pits using a trackhoe and operator provided by ESNW. The approximate locations of the test pits are illustrated on Plate 2 of this study. The test pit logs are provided in this Appendix. The test pits were advanced to a maximum depth of approximately seven and one-half feet bgs.

The final logs represent the interpretations of the field logs and the results of laboratory analyses. The stratification lines on the logs represent the approximate boundaries between soil types. In actuality, the transitions may be more gradual.

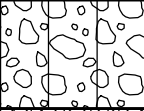
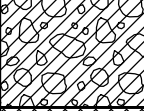
# Earth Solutions NW<sub>LLC</sub>

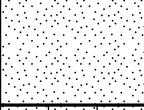
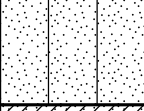
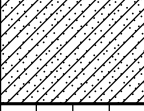
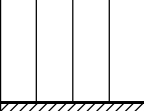
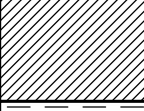
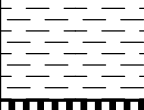
## SOIL CLASSIFICATION CHART

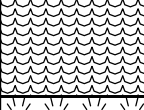
MAJOR DIVISIONS			SYMBOLS		TYPICAL DESCRIPTIONS
			GRAPH	LETTER	
<p><b>COARSE GRAINED SOILS</b></p> <p>MORE THAN 50% OF MATERIAL IS LARGER THAN NO. 200 SIEVE SIZE</p>	<p><b>GRAVEL AND GRAVELLY SOILS</b></p>	<p>CLEAN GRAVELS</p> <p>(LITTLE OR NO FINES)</p>		<b>GW</b>	WELL-GRADED GRAVELS, GRAVEL - SAND MIXTURES, LITTLE OR NO FINES
		<p>GRAVELS WITH FINES</p> <p>(APPRECIABLE AMOUNT OF FINES)</p>		<b>GP</b>	POORLY-GRADED GRAVELS, GRAVEL - SAND MIXTURES, LITTLE OR NO FINES
		<p>GRAVELS WITH FINES</p> <p>(APPRECIABLE AMOUNT OF FINES)</p>		<b>GM</b>	SILTY GRAVELS, GRAVEL - SAND - SILT MIXTURES
	<p><b>SAND AND SANDY SOILS</b></p>	<p>CLEAN SANDS</p> <p>(LITTLE OR NO FINES)</p>		<b>SW</b>	WELL-GRADED SANDS, GRAVELLY SANDS, LITTLE OR NO FINES
				<b>SP</b>	POORLY-GRADED SANDS, GRAVELLY SAND, LITTLE OR NO FINES
		<p><b>SANDS WITH FINES</b></p> <p>(APPRECIABLE AMOUNT OF FINES)</p>		<b>SM</b>	SILTY SANDS, SAND - SILT MIXTURES
			<b>SC</b>	CLAYEY SANDS, SAND - CLAY MIXTURES	
	<p><b>FINE GRAINED SOILS</b></p> <p>MORE THAN 50% OF MATERIAL IS SMALLER THAN NO. 200 SIEVE SIZE</p>	<p><b>SILTS AND CLAYS</b></p> <p>LIQUID LIMIT LESS THAN 50</p>		<b>ML</b>	INORGANIC SILTS AND VERY FINE SANDS, ROCK FLOUR, SILTY OR CLAYEY FINE SANDS OR CLAYEY SILTS WITH SLIGHT PLASTICITY
				<b>CL</b>	INORGANIC CLAYS OF LOW TO MEDIUM PLASTICITY, GRAVELLY CLAYS, SANDY CLAYS, SILTY CLAYS, LEAN CLAYS
			<b>OL</b>	ORGANIC SILTS AND ORGANIC SILTY CLAYS OF LOW PLASTICITY	
<p><b>SILTS AND CLAYS</b></p> <p>LIQUID LIMIT GREATER THAN 50</p>			<b>MH</b>	INORGANIC SILTS, MICACEOUS OR DIATOMACEOUS FINE SAND OR SILTY SOILS	
			<b>CH</b>	INORGANIC CLAYS OF HIGH PLASTICITY	
			<b>OH</b>	ORGANIC CLAYS OF MEDIUM TO HIGH PLASTICITY, ORGANIC SILTS	
<p><b>HIGHLY ORGANIC SOILS</b></p>				<b>PT</b>	PEAT, HUMUS, SWAMP SOILS WITH HIGH ORGANIC CONTENTS

DUAL SYMBOLS are used to indicate borderline soil classifications.

The discussion in the text of this report is necessary for a proper understanding of the nature of the material presented in the attached logs.



Earth Solutions NW, LLC  
 15365 N.E. 90th Street, Suite 100  
 Redmond, Washington 98052  
 Telephone: 425-449-4704  
 Fax: 425-449-4711

# TEST PIT NUMBER TP-1

PAGE 1 OF 1

PROJECT NUMBER ES-7526 PROJECT NAME Merlino SFR  
 DATE STARTED 10/8/20 COMPLETED 10/8/20 GROUND ELEVATION \_\_\_\_\_ TEST PIT SIZE \_\_\_\_\_  
 EXCAVATION CONTRACTOR NW Excavating GROUND WATER LEVELS:  
 EXCAVATION METHOD \_\_\_\_\_ AT TIME OF EXCAVATION ---  
 LOGGED BY AZS CHECKED BY HTW AT END OF EXCAVATION ---  
 NOTES Surface Conditions: grass AFTER EXCAVATION ---

DEPTH (ft)	SAMPLE TYPE NUMBER	TESTS	U.S.C.S.	GRAPHIC LOG	MATERIAL DESCRIPTION
0			SM		0.5 Brownish gray silty SAND, loose, moist (Fill)
			TPSL		1.5 Dark brown TOPSOIL, roots
		MC = 3.9%	SP-SM		3.0 Brown poorly graded SAND with silt, medium dense, moist
		MC = 2.8% Fines = 0.7%	SP		5.0 Gray poorly graded SAND with gravel, medium dense, moist
		MC = 18.2% Fines = 2.6%			7.5 [USDA Classification: very gravelly LOAM]

Test pit terminated at 7.5 feet below existing grade. No groundwater encountered during excavation. No caving observed.







Earth Solutions NW, LLC  
 15365 N.E. 90th Street, Suite 100  
 Redmond, Washington 98052  
 Telephone: 425-449-4704  
 Fax: 425-449-4711

# TEST PIT NUMBER TP-2

PAGE 1 OF 1

PROJECT NUMBER ES-7526 PROJECT NAME Merlino SFR  
 DATE STARTED 10/8/20 COMPLETED 10/8/20 GROUND ELEVATION \_\_\_\_\_ TEST PIT SIZE \_\_\_\_\_  
 EXCAVATION CONTRACTOR NW Excavating GROUND WATER LEVELS:  
 EXCAVATION METHOD \_\_\_\_\_ AT TIME OF EXCAVATION ---  
 LOGGED BY AZS CHECKED BY HTW AT END OF EXCAVATION ---  
 NOTES Surface Conditions: grass AFTER EXCAVATION ---

DEPTH (ft)	SAMPLE TYPE NUMBER	TESTS	U.S.C.S.	GRAPHIC LOG	MATERIAL DESCRIPTION
0					
		MC = 14.4%	SM	 0.5	Brownish gray silty SAND, loose, moist (Fill)
			TPSL	 1.0	Dark brown TOPSOIL
		MC = 14.2% Fines = 34.7%	SM	 2.5	Brown silty SAND, loose to medium dense, moist
			GM	 7.0	Gray silty GRAVEL with sand, medium dense to dense, moist [USDA Classification: very gravelly LOAM]  -weakly cemented, iron oxide staining
5					
		MC = 11.8%			

Test pit terminated at 7.0 feet below existing grade. No groundwater encountered during excavation. No caving observed.



**Appendix B**  
**Laboratory Test Results**  
**ES-7526**



Earth Solutions NW, LLC  
 15365 N.E. 90th Street, Suite 100  
 Redmond, Washington 98052  
 Telephone: 425-449-4704  
 Fax: 425-449-4711

# GRAIN SIZE DISTRIBUTION

PROJECT NUMBER ES-7526

PROJECT NAME Merlino SFR

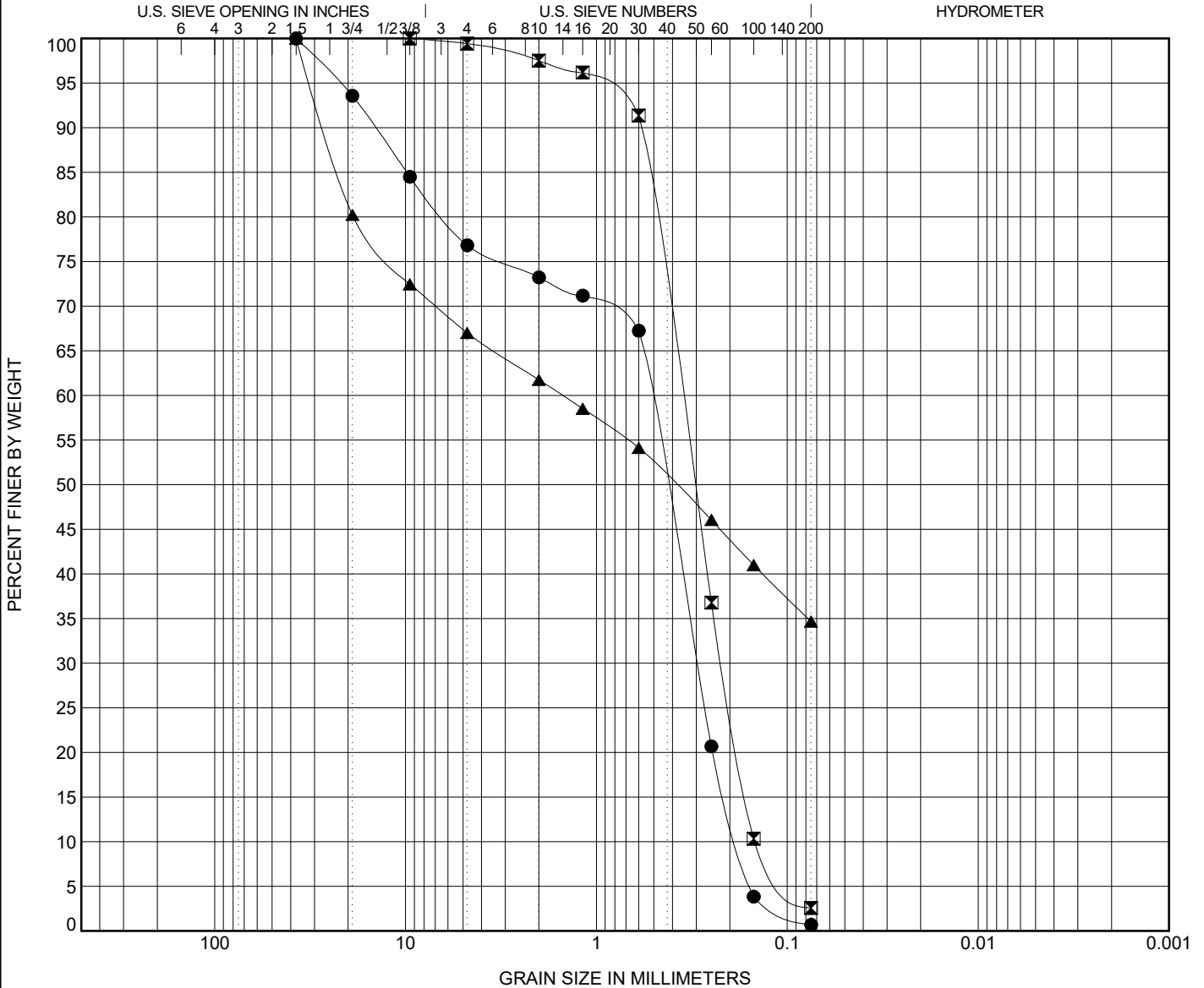

COBBLES	GRAVEL		SAND			SILT OR CLAY
	coarse	fine	coarse	medium	fine	

Specimen Identification			Classification					Cc	Cu		
●	TP-01	4.00ft.	USDA: Gray Gravelly Sand. USCS: SP with Gravel.					0.94	2.90		
⊠	TP-01	7.50ft.	USDA: Gray Slightly Gravelly Sand. USCS: SP.					0.91	2.49		
▲	TP-02	3.00ft.	USDA: Gray Very Gravelly Loam. USCS: GM with Sand.								
Specimen Identification			D100	D60	D30	D10	LL	PL	PI	%Silt	%Clay
●	TP-01	4.0ft.	37.5	0.524	0.298	0.181				0.7	
⊠	TP-01	7.5ft.	9.5	0.363	0.219	0.146				2.6	
▲	TP-02	3.0ft.	37.5	1.503						34.7	

GRAIN SIZE USDA ES-7526 MERLINO SFR.GPJ GINT US LAB.GDT 10/19/20

**Report Distribution**

**ES-7526**

**EMAIL ONLY**

**Mr. John Merlino  
c/o Century Communities  
16108 Ash Way, Suite 201  
Lynnwood, Washington 98087**

# Chapter 4 - Best Management Practices Standards and Specifications

Best Management Practices (BMPs) are defined as schedules of activities, prohibitions of practices, maintenance procedures, and structural and/or managerial practices, that when used singly or in combination, prevent or reduce the release of pollutants to waters of Washington State. This chapter contains standards and specifications for temporary BMPs to be used as applicable during the construction phase of a project. Often using BMPs in combination is the best method to meet Construction Stormwater Pollution Prevention Plan (SWPPP) requirements.

None of the BMPs listed below will work successfully through the construction project without inspection and maintenance. Regular inspections to identify problems with the operation of each BMP, and the timely repair of any problems are essential to the continued operation of the BMPs.

[Section 4.1](#) contains the standards and specifications for Source Control BMPs.

[Section 4.2](#) contains the standards and specifications for Runoff Conveyance and Treatment BMPs.

The standards for each individual BMP are divided into four sections:

1. Purpose
2. Conditions of Use
3. Design and Installation Specifications
4. Maintenance Standards

Note that the “Conditions of Use” refers to site conditions. As site conditions change, BMPs must be changed to remain in compliance.

## 4.1 Source Control BMPs

This section contains the standards and specifications for Source Control BMPs. [Table 4.1.1](#), below, shows the relationship of the BMPs in Section 4.1 to the Construction Stormwater Pollution Prevention Plan (SWPPP) [Elements](#) described in [Section 3.3.3](#). Elements not shown on [Table 4.1.1](#) are not satisfied through installation of Source Controls.

**Table 4.1.1 Source Control BMPs by SWPPP Element**

<b>BMP or Element Name</b>	<b>Element #1</b> Preserve Vegetation/ Mark Clearing Limits	<b>Element #2</b> Establish Construction Access	<b>Element #5</b> Stabilize Soils	<b>Element #6</b> Protect Slopes	<b>Element #8</b> Stabilize Channels and Outlets	<b>Element #9</b> Control Pollutants	<b>Element #11</b> Maintain BMPs	<b>Element #12</b> Manage the Project	<b>Element #13</b> Protect Low Impact Development
<b>BMP C101:</b> Preserving Natural Vegetation	✓								
<b>BMP C102:</b> Buffer Zones	✓								✓
<b>BMP C103:</b> High Visibility Fence	✓								✓
<b>BMP C105:</b> Stabilized Construction Entrance / Exit		✓							
<b>BMP C106:</b> Wheel Wash		✓							
<b>BMP C107:</b> Construction Road/Parking Area Stabilization		✓							
<b>BMP C120:</b> Temporary and Permanent Seeding			✓	✓					
<b>BMP C121:</b> Mulching			✓	✓					
<b>BMP C122:</b> Nets and Blankets			✓	✓	✓				
<b>BMP C123:</b> Plastic Covering			✓	✓					
<b>BMP C124:</b> Sodding			✓	✓					
<b>BMP C125:</b> Topsoiling / Composting			✓						
<b>BMP C126:</b> Polyacrylamide (PAM) for Soil Erosion Protection			✓						
<b>BMP C130:</b> Surface Roughening			✓	✓					
<b>BMP C131:</b> Gradient Terraces			✓	✓					
<b>BMP C140:</b> Dust Control			✓						
<b>BMP C150:</b> Materials on Hand							✓	✓	
<b>BMP C151:</b> Concrete Handling						✓			
<b>BMP C152:</b> Sawcutting and Surfacing Pollution Prevention						✓			
<b>BMP C153:</b> Material Delivery, Storage and Containment						✓			
<b>BMP C154:</b> Concrete Washout Area						✓			
<b>BMP C160:</b> Certified Erosion and Sediment Control Lead							✓	✓	
<b>BMP C162:</b> Scheduling								✓	

## **BMP C101: Preserving Natural Vegetation**

***Purpose*** The purpose of preserving natural vegetation is to reduce erosion wherever practicable. Limiting site disturbance is the single most effective method for reducing erosion. For example, conifers can hold up to about 50 percent of all rain that falls during a storm. Up to 20-30 percent of this rain may never reach the ground but is taken up by the tree or evaporates. Another benefit is that the rain held in the tree can be released slowly to the ground after the storm.

***Conditions of Use*** Natural vegetation should be preserved on steep slopes, near perennial and intermittent watercourses or swales, and on building sites in wooded areas.

- As required by local governments.
- Phase construction to preserve natural vegetation on the project site for as long as possible during the construction period.

***Design and Installation Specifications*** Natural vegetation can be preserved in natural clumps or as individual trees, shrubs and vines.

The preservation of individual plants is more difficult because heavy equipment is generally used to remove unwanted vegetation. The points to remember when attempting to save individual plants are:

- Is the plant worth saving? Consider the location, species, size, age, vigor, and the work involved. Local governments may also have ordinances to save natural vegetation and trees.
- Fence or clearly mark areas around trees that are to be saved. It is preferable to keep ground disturbance away from the trees at least as far out as the dripline.

Plants need protection from three kinds of injuries:

- *Construction Equipment* - This injury can be above or below the ground level. Damage results from scarring, cutting of roots, and compaction of the soil. Placing a fenced buffer zone around plants to be saved prior to construction can prevent construction equipment injuries.
- *Grade Changes* - Changing the natural ground level will alter grades, which affects the plant's ability to obtain the necessary air, water, and minerals. Minor fills usually do not cause problems although sensitivity between species does vary and should be checked. Trees can typically tolerate fill of 6 inches or less. For shrubs and other plants, the fill should be less.

When there are major changes in grade, it may become necessary to supply air to the roots of plants. This can be done by placing a layer of gravel and a tile system over the roots before the fill is made. A tile

system protects a tree from a raised grade. The tile system should be laid out on the original grade leading from a dry well around the tree trunk. The system should then be covered with small stones to allow air to circulate over the root area.

Lowering the natural ground level can seriously damage trees and shrubs. The highest percentage of the plant roots are in the upper 12 inches of the soil and cuts of only 2-3 inches can cause serious injury. To protect the roots it may be necessary to terrace the immediate area around the plants to be saved. If roots are exposed, construction of retaining walls may be needed to keep the soil in place. Plants can also be preserved by leaving them on an undisturbed, gently sloping mound. To increase the chances for survival, it is best to limit grade changes and other soil disturbances to areas outside the dripline of the plant.

- *Excavations* - Protect trees and other plants when excavating for drainfields, power, water, and sewer lines. Where possible, the trenches should be routed around trees and large shrubs. When this is not possible, it is best to tunnel under them. This can be done with hand tools or with power augers. If it is not possible to route the trench around plants to be saved, then the following should be observed:

Cut as few roots as possible. When you have to cut, cut clean. Paint cut root ends with a wood dressing like asphalt base paint if roots will be exposed for more than 24-hours.

Backfill the trench as soon as possible.

Tunnel beneath root systems as close to the center of the main trunk to preserve most of the important feeder roots.

Some problems that can be encountered with a few specific trees are:

- Maple, Dogwood, Red alder, Western hemlock, Western red cedar, and Douglas fir do not readily adjust to changes in environment and special care should be taken to protect these trees.
- The windthrow hazard of Pacific silver fir and madrona is high, while that of Western hemlock is moderate. The danger of windthrow increases where dense stands have been thinned. Other species (unless they are on shallow, wet soils less than 20 inches deep) have a low windthrow hazard.
- Cottonwoods, maples, and willows have water-seeking roots. These can cause trouble in sewer lines and infiltration fields. On the other hand, they thrive in high moisture conditions that other trees would not.
- Thinning operations in pure or mixed stands of Grand fir, Pacific silver fir, Noble fir, Sitka spruce, Western red cedar, Western hemlock, Pacific dogwood, and Red alder can cause serious disease problems.

Disease can become established through damaged limbs, trunks, roots, and freshly cut stumps. Diseased and weakened trees are also susceptible to insect attack.

***Maintenance Standards***

Inspect flagged and/or fenced areas regularly to make sure flagging or fencing has not been removed or damaged. If the flagging or fencing has been damaged or visibility reduced, it shall be repaired or replaced immediately and visibility restored.

- If tree roots have been exposed or injured, “prune” cleanly with an appropriate pruning saw or loppers directly above the damaged roots and recover with native soils. Treatment of sap flowing trees (fir, hemlock, pine, soft maples) is not advised as sap forms a natural healing barrier.

**BMP C102: Buffer Zones**

***Purpose***

Creation of an undisturbed area or strip of natural vegetation or an established suitable planting that will provide a living filter to reduce soil erosion and runoff velocities.

***Conditions of Use***

Natural buffer zones are used along streams, wetlands and other bodies of water that need protection from erosion and sedimentation. Vegetative buffer zones can be used to protect natural swales and can be incorporated into the natural landscaping of an area.

Critical-areas buffer zones should not be used as sediment treatment areas. These areas shall remain completely undisturbed. The local permitting authority may expand the buffer widths temporarily to allow the use of the expanded area for removal of sediment.

***Design and Installation Specifications***

- Preserving natural vegetation or plantings in clumps, blocks, or strips is generally the easiest and most successful method.
- Leave all unstable steep slopes in natural vegetation.
- Mark clearing limits and keep all equipment and construction debris out of the natural areas and buffer zones. Steel construction fencing is the most effective method in protecting sensitive areas and buffers. Alternatively, wire-backed silt fence on steel posts is marginally effective. Flagging alone is typically not effective.
- Keep all excavations outside the dripline of trees and shrubs.
- Do not push debris or extra soil into the buffer zone area because it will cause damage from burying and smothering.
- Vegetative buffer zones for streams, lakes or other waterways shall be established by the local permitting authority or other state or federal permits or approvals.

***Maintenance Standards***

Inspect the area frequently to make sure flagging remains in place and the area remains undisturbed. Replace all damaged flagging immediately.



## **BMP C103: High Visibility Fence**

<b><i>Purpose</i></b>	Fencing is intended to: <ol style="list-style-type: none"><li>1. Restrict clearing to approved limits.</li><li>2. Prevent disturbance of sensitive areas, their buffers, and other areas required to be left undisturbed.</li><li>3. Limit construction traffic to designated construction entrances, exits, or internal roads.</li><li>4. Protect areas where marking with survey tape may not provide adequate protection.</li></ol>
<b><i>Conditions of Use</i></b>	To establish clearing limits plastic, fabric, or metal fence may be used: <ul style="list-style-type: none"><li>• At the boundary of sensitive areas, their buffers, and other areas required to be left uncleared.</li><li>• As necessary to control vehicle access to and on the site.</li></ul>
<b><i>Design and Installation Specifications</i></b>	<p>High visibility plastic fence shall be composed of a high-density polyethylene material and shall be at least four feet in height. Posts for the fencing shall be steel or wood and placed every 6 feet on center (maximum) or as needed to ensure rigidity. The fencing shall be fastened to the post every six inches with a polyethylene tie. On long continuous lengths of fencing, a tension wire or rope shall be used as a top stringer to prevent sagging between posts. The fence color shall be high visibility orange. The fence tensile strength shall be 360 lbs./ft. using the ASTM D4595 testing method.</p> <p>If appropriate install fabric silt fence in accordance with <a href="#">BMP C233</a> to act as high visibility fence. Silt fence shall be at least 3 feet high and must be highly visible to meet the requirements of this BMP.</p> <p>Metal fences shall be designed and installed according to the manufacturer's specifications.</p> <p>Metal fences shall be at least 3 feet high and must be highly visible.</p> <p>Fences shall not be wired or stapled to trees.</p>
<b><i>Maintenance Standards</i></b>	If the fence has been damaged or visibility reduced, it shall be repaired or replaced immediately and visibility restored.

## **BMP C105: Stabilized Construction Entrance / Exit**

### ***Purpose***

Stabilized Construction entrances are established to reduce the amount of sediment transported onto paved roads by vehicles or equipment. This is done by constructing a stabilized pad of quarry spalls at entrances and exits for construction sites.

### ***Conditions of Use***

Construction entrances shall be stabilized wherever traffic will be entering or leaving a construction site if paved roads or other paved areas are within 1,000 feet of the site.

For residential construction provide stabilized construction entrances for each residence, rather than only at the main subdivision entrance. Stabilized surfaces shall be of sufficient length/width to provide vehicle access/parking, based on lot size/configuration.

On large commercial, highway, and road projects, the designer should include enough extra materials in the contract to allow for additional stabilized entrances not shown in the initial Construction SWPPP. It is difficult to determine exactly where access to these projects will take place; additional materials will enable the contractor to install them where needed.

### ***Design and Installation Specifications***

See [Figure 4.1.1](#) for details. Note: the 100' minimum length of the entrance shall be reduced to the maximum practicable size when the size or configuration of the site does not allow the full length (100').

Construct stabilized construction entrances with a 12-inch thick pad of 4-inch to 8-inch quarry spalls, a 4-inch course of asphalt treated base (ATB), or use existing pavement. Do not use crushed concrete, cement, or calcium chloride for construction entrance stabilization because these products raise pH levels in stormwater and concrete discharge to surface waters of the State is prohibited.

A separation geotextile shall be placed under the spalls to prevent fine sediment from pumping up into the rock pad. The geotextile shall meet the following standards:

Grab Tensile Strength (ASTM D4751)	200 psi min.
Grab Tensile Elongation (ASTM D4632)	30% max.
Mullen Burst Strength (ASTM D3786-80a)	400 psi min.
AOS (ASTM D4751)	20-45 (U.S. standard sieve size)

- Consider early installation of the first lift of asphalt in areas that will paved; this can be used as a stabilized entrance. Also consider the installation of excess concrete as a stabilized entrance. During large concrete pours, excess concrete is often available for this purpose.

- Fencing (see [BMP C103](#)) shall be installed as necessary to restrict traffic to the construction entrance.
- Whenever possible, the entrance shall be constructed on a firm, compacted subgrade. This can substantially increase the effectiveness of the pad and reduce the need for maintenance.
- Construction entrances should avoid crossing existing sidewalks and back of walk drains if at all possible. If a construction entrance must cross a sidewalk or back of walk drain, the full length of the sidewalk and back of walk drain must be covered and protected from sediment leaving the site.

***Maintenance Standards***

Quarry spalls shall be added if the pad is no longer in accordance with the specifications.

- If the entrance is not preventing sediment from being tracked onto pavement, then alternative measures to keep the streets free of sediment shall be used. This may include replacement/cleaning of the existing quarry spalls, street sweeping, an increase in the dimensions of the entrance, or the installation of a wheel wash.
- Any sediment that is tracked onto pavement shall be removed by shoveling or street sweeping. The sediment collected by sweeping shall be removed or stabilized on site. The pavement shall not be cleaned by washing down the street, except when high efficiency sweeping is ineffective and there is a threat to public safety. If it is necessary to wash the streets, the construction of a small sump to contain the wash water shall be considered. The sediment would then be washed into the sump where it can be controlled.
- Perform street sweeping by hand or with a high efficiency sweeper. Do not use a non-high efficiency mechanical sweeper because this creates dust and throws soils into storm systems or conveyance ditches.
- Any quarry spalls that are loosened from the pad, which end up on the roadway shall be removed immediately.
- If vehicles are entering or exiting the site at points other than the construction entrance(s), fencing (see [BMP C103](#)) shall be installed to control traffic.
- Upon project completion and site stabilization, all construction accesses intended as permanent access for maintenance shall be permanently stabilized.

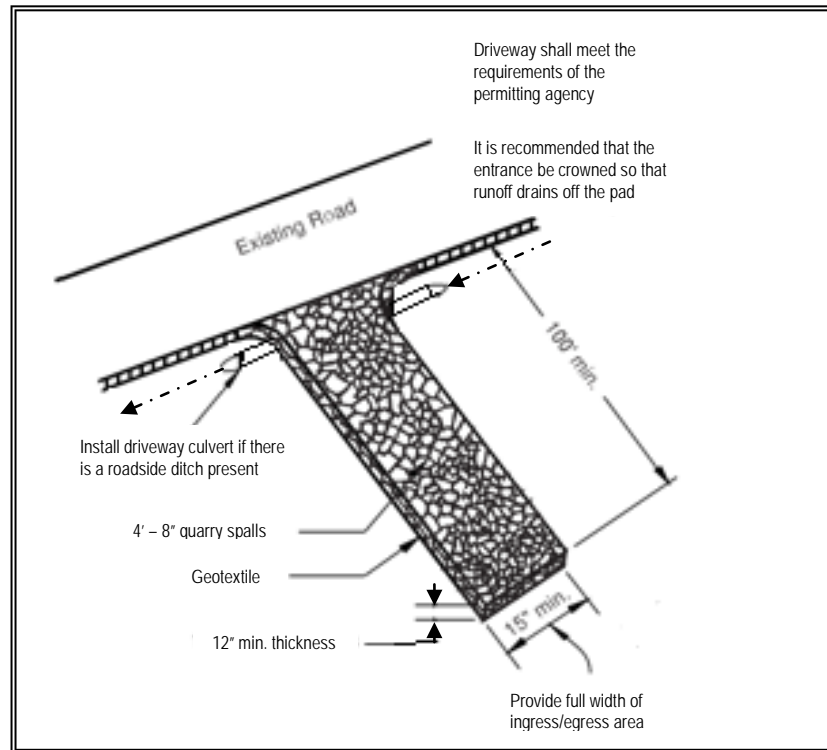

**Figure 4.1.1 – Stabilized Construction Entrance**

***Approved as Equivalent***

Ecology has approved products as able to meet the requirements of [BMP C105](#). The products did not pass through the Technology Assessment Protocol – Ecology (TAPE) process. Local jurisdictions may choose not to accept this product approved as equivalent, or may require additional testing prior to consideration for local use. The products are available for review on Ecology’s website at <http://www.ecy.wa.gov/programs/wq/stormwater/newtech/equivalent.html>

**BMP C106: Wheel Wash**

***Purpose***

Wheel washes reduce the amount of sediment transported onto paved roads by motor vehicles.

***Conditions of Use***

When a stabilized construction entrance (see [BMP C105](#)) is not preventing sediment from being tracked onto pavement.

- Wheel washing is generally an effective BMP when installed with careful attention to topography. For example, a wheel wash can be detrimental if installed at the top of a slope abutting a right-of-way where the water from the dripping truck can run unimpeded into the street.

- Pressure washing combined with an adequately sized and surfaced pad with direct drainage to a large 10-foot x 10-foot sump can be very effective.
- Discharge wheel wash or tire bath wastewater to a separate on-site treatment system that prevents discharge to surface water, such as closed-loop recirculation or upland land application, or to the sanitary sewer with local sewer district approval.
- Wheel wash or tire bath wastewater should not include wastewater from concrete washout areas.

***Design and  
Installation  
Specifications***

Suggested details are shown in [Figure 4.1.2](#). The Local Permitting Authority may allow other designs. A minimum of 6 inches of asphalt treated base (ATB) over crushed base material or 8 inches over a good subgrade is recommended to pave the wheel wash.

Use a low clearance truck to test the wheel wash before paving. Either a belly dump or lowboy will work well to test clearance.

Keep the water level from 12 to 14 inches deep to avoid damage to truck hubs and filling the truck tongues with water.

Midpoint spray nozzles are only needed in extremely muddy conditions.

Wheel wash systems should be designed with a small grade change, 6- to 12-inches for a 10-foot-wide pond, to allow sediment to flow to the low side of pond to help prevent re-suspension of sediment. A drainpipe with a 2- to 3-foot riser should be installed on the low side of the pond to allow for easy cleaning and refilling. Polymers may be used to promote coagulation and flocculation in a closed-loop system. Polyacrylamide (PAM) added to the wheel wash water at a rate of 0.25 - 0.5 pounds per 1,000 gallons of water increases effectiveness and reduces cleanup time. If PAM is already being used for dust or erosion control and is being applied by a water truck, the same truck can be used to change the wash water.

***Maintenance  
Standards***

The wheel wash should start out the day with fresh water.

The wash water should be changed a minimum of once per day. On large earthwork jobs where more than 10-20 trucks per hour are expected, the wash water will need to be changed more often.

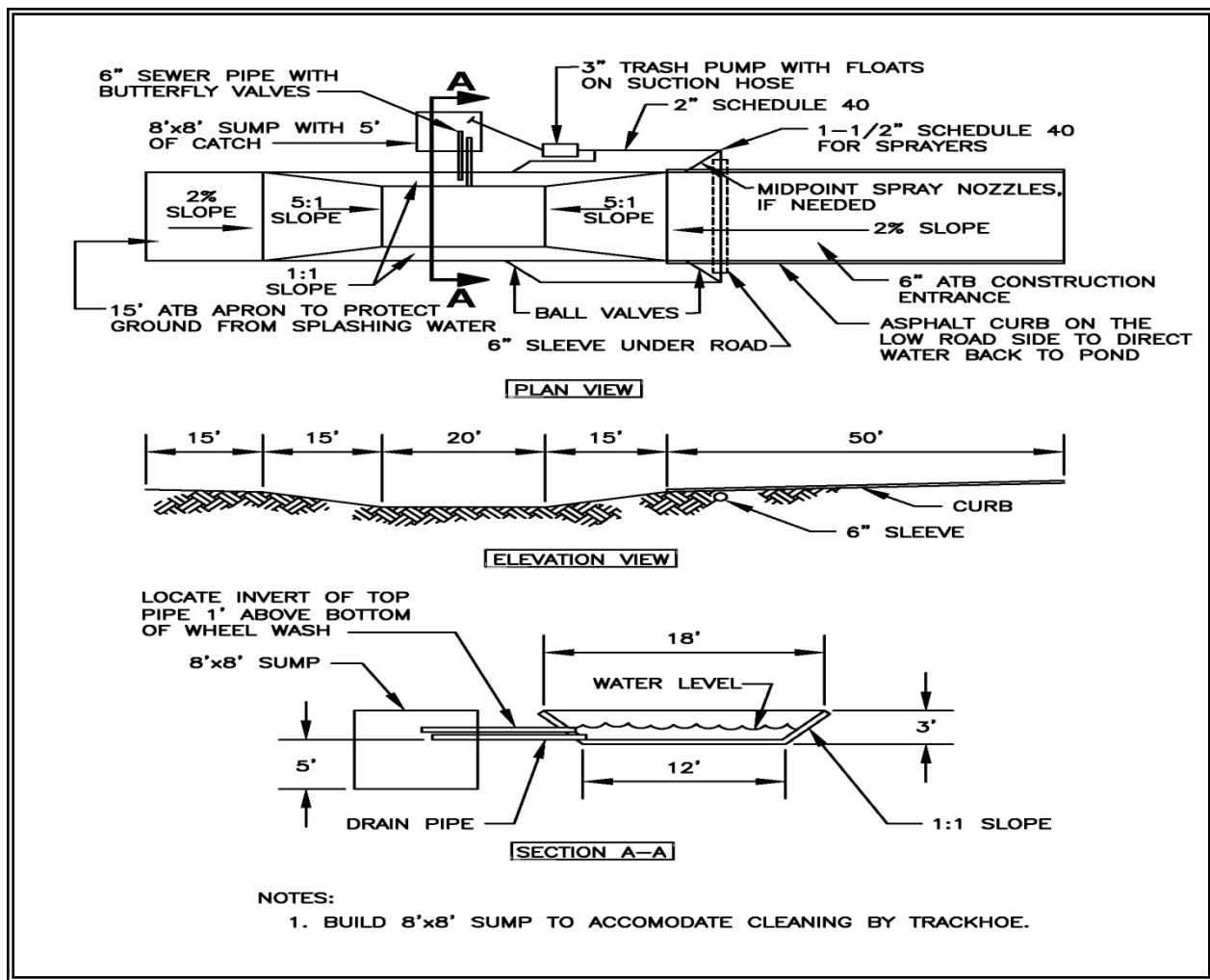

Figure 4.1.2 – Wheel Wash

Notes:

1. Asphalt construction entrance 6 in. asphalt treated base (ATB).
2. 3-inch trash pump with floats on the suction hose.
3. Midpoint spray nozzles, if needed.
4. 6-inch sewer pipe with butterfly valves. Bottom one is a drain. Locate top pipe's invert 1 foot above bottom of wheel wash.
5. 8 foot x 8 foot sump with 5 feet of catch. Build so the sump can be cleaned with a trackhoe.
6. Asphalt curb on the low road side to direct water back to pond.
7. 6-inch sleeve under road.
8. Ball valves.
9. 15 foot. ATB apron to protect ground from splashing water.

## **BMP C107: Construction Road/Parking Area Stabilization**

<i><b>Purpose</b></i>	Stabilizing subdivision roads, parking areas, and other on-site vehicle transportation routes immediately after grading reduces erosion caused by construction traffic or runoff.
<i><b>Conditions of Use</b></i>	Roads or parking areas shall be stabilized wherever they are constructed, whether permanent or temporary, for use by construction traffic. <ul style="list-style-type: none"><li>• High Visibility Fencing (see <a href="#">BMP C103</a>) shall be installed, if necessary, to limit the access of vehicles to only those roads and parking areas that are stabilized.</li></ul>
<i><b>Design and Installation Specifications</b></i>	<ul style="list-style-type: none"><li>• On areas that will receive asphalt as part of the project, install the first lift as soon as possible.</li><li>• A 6-inch depth of 2- to 4-inch crushed rock, gravel base, or crushed surfacing base course shall be applied immediately after grading or utility installation. A 4-inch course of asphalt treated base (ATB) may also be used, or the road/parking area may be paved. It may also be possible to use cement or calcium chloride for soil stabilization. If cement or cement kiln dust is used for roadbase stabilization, pH monitoring and BMPs (<a href="#">BMPs C252</a> and <a href="#">C253</a>) are necessary to evaluate and minimize the effects on stormwater. If the area will not be used for permanent roads, parking areas, or structures, a 6-inch depth of hog fuel may also be used, but this is likely to require more maintenance. Whenever possible, construction roads and parking areas shall be placed on a firm, compacted subgrade.</li><li>• Temporary road gradients shall not exceed 15 percent. Roadways shall be carefully graded to drain. Drainage ditches shall be provided on each side of the roadway in the case of a crowned section, or on one side in the case of a super-elevated section. Drainage ditches shall be directed to a sediment control BMP.</li><li>• Rather than relying on ditches, it may also be possible to grade the road so that runoff sheet-flows into a heavily vegetated area with a well-developed topsoil. Landscaped areas are not adequate. If this area has at least 50 feet of vegetation that water can flow through, then it is generally preferable to use the vegetation to treat runoff, rather than a sediment pond or trap. The 50 feet shall not include wetlands or their buffers. If runoff is allowed to sheetflow through adjacent vegetated areas, it is vital to design the roadways and parking areas so that no concentrated runoff is created.</li><li>• Storm drain inlets shall be protected to prevent sediment-laden water entering the storm drain system (see <a href="#">BMP C220</a>).</li></ul>
<i><b>Maintenance Standards</b></i>	Inspect stabilized areas regularly, especially after large storm events. Crushed rock, gravel base, etc., shall be added as required to maintain a

stable driving surface and to stabilize any areas that have eroded.

Following construction, these areas shall be restored to pre-construction condition or better to prevent future erosion.

Perform street cleaning at the end of each day or more often if necessary.

## **BMP C120: Temporary and Permanent Seeding**

**Purpose** Seeding reduces erosion by stabilizing exposed soils. A well-established vegetative cover is one of the most effective methods of reducing erosion.

**Conditions of Use** Use seeding throughout the project on disturbed areas that have reached final grade or that will remain unworked for more than 30 days.

The optimum seeding windows for western Washington are April 1 through June 30 and September 1 through October 1.

Between July 1 and August 30 seeding requires irrigation until 75 percent grass cover is established.

Between October 1 and March 30 seeding requires a cover of mulch with straw or an erosion control blanket until 75 percent grass cover is established.

Review all disturbed areas in late August to early September and complete all seeding by the end of September. Otherwise, vegetation will not establish itself enough to provide more than average protection.

- Mulch is required at all times for seeding because it protects seeds from heat, moisture loss, and transport due to runoff. Mulch can be applied on top of the seed or simultaneously by hydroseeding. See [BMP C121: Mulching](#) for specifications.
- Seed and mulch, all disturbed areas not otherwise vegetated at final site stabilization. Final stabilization means the completion of all soil disturbing activities at the site and the establishment of a permanent vegetative cover, or equivalent permanent stabilization measures (such as pavement, riprap, gabions, or geotextiles) which will prevent erosion.

### ***Design and Installation Specifications***

Seed retention/detention ponds as required.

Install channels intended for vegetation before starting major earthwork and hydroseed with a Bonded Fiber Matrix. For vegetated channels that will have high flows, install erosion control blankets over hydroseed. Before allowing water to flow in vegetated channels, establish 75 percent vegetation cover. If vegetated channels cannot be established by seed before water flow; install sod in the channel bottom—over hydromulch and erosion control blankets.



- Confirm the installation of all required surface water control measures to prevent seed from washing away.
  - Hydroseed applications shall include a minimum of 1,500 pounds per acre of mulch with 3 percent tackifier. See [BMP C121: Mulching](#) for specifications.
  - Areas that will have seeding only and not landscaping may need compost or meal-based mulch included in the hydroseed in order to establish vegetation. Re-install native topsoil on the disturbed soil surface before application.
  - When installing seed via hydroseeding operations, only about 1/3 of the seed actually ends up in contact with the soil surface. This reduces the ability to establish a good stand of grass quickly. To overcome this, consider increasing seed quantities by up to 50 percent.
  - Enhance vegetation establishment by dividing the hydromulch operation into two phases:
    1. Phase 1- Install all seed and fertilizer with 25-30 percent mulch and tackifier onto soil in the first lift.
    2. Phase 2- Install the rest of the mulch and tackifier over the first lift.
- Or, enhance vegetation by:
1. Installing the mulch, seed, fertilizer, and tackifier in one lift.
  2. Spread or blow straw over the top of the hydromulch at a rate of 800-1000 pounds per acre.
  3. Hold straw in place with a standard tackifier.

Both of these approaches will increase cost moderately but will greatly improve and enhance vegetative establishment. The increased cost may be offset by the reduced need for:

- Irrigation.
- Reapplication of mulch.
- Repair of failed slope surfaces.

This technique works with standard hydromulch (1,500 pounds per acre minimum) and BFM/MBFMs (3,000 pounds per acre minimum).

- Seed may be installed by hand if:
  - Temporary and covered by straw, mulch, or topsoil.
  - Permanent in small areas (usually less than 1 acre) and covered with mulch, topsoil, or erosion blankets.
  - The seed mixes listed in the tables below include recommended mixes for both temporary and permanent seeding.

- Apply these mixes, with the exception of the wetland mix, at a rate of 120 pounds per acre. This rate can be reduced if soil amendments or slow-release fertilizers are used.
- Consult the local suppliers or the local conservation district for their recommendations because the appropriate mix depends on a variety of factors, including location, exposure, soil type, slope, and expected foot traffic. Alternative seed mixes approved by the local authority may be used.
- Other mixes may be appropriate, depending on the soil type and hydrology of the area.
- [Table 4.1.2](#) lists the standard mix for areas requiring a temporary vegetative cover.

<b>Table 4.1.2 Temporary Erosion Control Seed Mix</b>			
	<b>% Weight</b>	<b>% Purity</b>	<b>% Germination</b>
Chewings or annual blue grass <i>Festuca rubra var. commutata</i> or <i>Poa anna</i>	40	98	90
Perennial rye - <i>Lolium perenne</i>	50	98	90
Redtop or colonial bentgrass <i>Agrostis alba</i> or <i>Agrostis tenuis</i>	5	92	85
White dutch clover <i>Trifolium repens</i>	5	98	90

- [Table 4.1.3](#) lists a recommended mix for landscaping seed.

<b>Table 4.1.3 Landscaping Seed Mix</b>			
	<b>% Weight</b>	<b>% Purity</b>	<b>% Germination</b>
Perennial rye blend <i>Lolium perenne</i>	70	98	90
Chewings and red fescue blend <i>Festuca rubra var. commutata</i> or <i>Festuca rubra</i>	30	98	90

- [Table 4.1.4](#) lists a turf seed mix for dry situations where there is no need for watering. This mix requires very little maintenance.

<b>Table 4.1.4 Low-Growing Turf Seed Mix</b>			
	% Weight	% Purity	% Germination
Dwarf tall fescue (several varieties) <i>Festuca arundinacea</i> var.	45	98	90
Dwarf perennial rye (Barclay) <i>Lolium perenne</i> var. <i>barclay</i>	30	98	90
Red fescue <i>Festuca rubra</i>	20	98	90
Colonial bentgrass <i>Agrostis tenuis</i>	5	98	90

- [Table 4.1.5](#) lists a mix for bioswales and other intermittently wet areas.

<b>Table 4.1.5 Bioswale Seed Mix*</b>			
	% Weight	% Purity	% Germination
Tall or meadow fescue <i>Festuca arundinacea</i> or <i>Festuca elatior</i>	75-80	98	90
Seaside/Creeping bentgrass <i>Agrostis palustris</i>	10-15	92	85
Redtop bentgrass <i>Agrostis alba</i> or <i>Agrostis gigantea</i>	5-10	90	80

\* Modified Briargreen, Inc. Hydroseeding Guide Wetlands Seed Mix

- [Table 4.1.6](#) lists a low-growing, relatively non-invasive seed mix appropriate for very wet areas that are not regulated wetlands. Apply this mixture at a rate of 60 pounds per acre. Consult Hydraulic Permit Authority (HPA) for seed mixes if applicable.

<b>Table 4.1.6 Wet Area Seed Mix*</b>			
	<b>% Weight</b>	<b>% Purity</b>	<b>% Germination</b>
Tall or meadow fescue <i>Festuca arundinacea</i> or <i>Festuca elatior</i>	60-70	98	90
Seaside/Creeping bentgrass <i>Agrostis palustris</i>	10-15	98	85
Meadow foxtail <i>Alepecurus pratensis</i>	10-15	90	80
Alsike clover <i>Trifolium hybridum</i>	1-6	98	90
Redtop bentgrass <i>Agrostis alba</i>	1-6	92	85

\* *Modified Briargreen, Inc. Hydroseeding Guide Wetlands Seed Mix*

- [Table 4.1.7](#) lists a recommended meadow seed mix for infrequently maintained areas or non-maintained areas where colonization by native plants is desirable. Likely applications include rural road and utility right-of-way. Seeding should take place in September or very early October in order to obtain adequate establishment prior to the winter months. Consider the appropriateness of clover, a fairly invasive species, in the mix. Amending the soil can reduce the need for clover.

<b>Table 4.1.7 Meadow Seed Mix</b>			
	<b>% Weight</b>	<b>% Purity</b>	<b>% Germination</b>
Redtop or Oregon bentgrass <i>Agrostis alba</i> or <i>Agrostis oregonensis</i>	20	92	85
Red fescue <i>Festuca rubra</i>	70	98	90
White dutch clover <i>Trifolium repens</i>	10	98	90

- **Roughening and Rototilling:**
  - The seedbed should be firm and rough. Roughen all soil no matter what the slope. Track walk slopes before seeding if engineering purposes require compaction. Backblading or smoothing of slopes greater than 4H:1V is not allowed if they are to be seeded.
  - Restoration-based landscape practices require deeper incorporation than that provided by a simple single-pass rototilling treatment. Wherever practical, initially rip the subgrade to improve long-term permeability, infiltration, and water inflow qualities. At a minimum, permanent areas shall use soil amendments to achieve organic matter and permeability performance defined in engineered soil/landscape systems. For systems that are deeper than 8 inches complete the rototilling process in multiple lifts, or prepare the engineered soil system per specifications and place to achieve the specified depth.
- **Fertilizers:**
  - Conducting soil tests to determine the exact type and quantity of fertilizer is recommended. This will prevent the over-application of fertilizer.
  - Organic matter is the most appropriate form of fertilizer because it provides nutrients (including nitrogen, phosphorus, and potassium) in the least water-soluble form.
  - In general, use 10-4-6 N-P-K (nitrogen-phosphorus-potassium) fertilizer at a rate of 90 pounds per acre. Always use slow-release fertilizers because they are more efficient and have fewer environmental impacts. Do not add fertilizer to the hydromulch machine, or agitate, more than 20 minutes before use. Too much agitation destroys the slow-release coating.
  - There are numerous products available that take the place of chemical fertilizers. These include several with seaweed extracts that are beneficial to soil microbes and organisms. If 100 percent cottonseed meal is used as the mulch in hydroseed, chemical fertilizer may not be necessary. Cottonseed meal provides a good source of long-term, slow-release, available nitrogen.
- **Bonded Fiber Matrix and Mechanically Bonded Fiber Matrix:**
  - On steep slopes use Bonded Fiber Matrix (BFM) or Mechanically Bonded Fiber Matrix (MBFM) products. Apply BFM/MBFM products at a minimum rate of 3,000 pounds per acre of mulch with approximately 10 percent tackifier. Achieve a minimum of 95 percent soil coverage during application. Numerous products are available commercially. Installed products per manufacturer's instructions. Most products require 24-36 hours to cure before rainfall and cannot be installed on wet or saturated soils.

Generally, products come in 40-50 pound bags and include all necessary ingredients except for seed and fertilizer.

- BFM and MBFMs provide good alternatives to blankets in most areas requiring vegetation establishment. Advantages over blankets include:
  - BFM and MBFMs do not require surface preparation.
  - Helicopters can assist in installing BFM and MBFMs in remote areas.
  - On slopes steeper than 2.5H:1V, blanket installers may require ropes and harnesses for safety.
  - Installing BFM and MBFMs can save at least \$1,000 per acre compared to blankets.

***Maintenance Standards***

Reseed any seeded areas that fail to establish at least 80 percent cover (100 percent cover for areas that receive sheet or concentrated flows). If reseeding is ineffective, use an alternate method such as sodding, mulching, or nets/blankets. If winter weather prevents adequate grass growth, this time limit may be relaxed at the discretion of the local authority when sensitive areas would otherwise be protected.

- Reseed and protect by mulch any areas that experience erosion after achieving adequate cover. Reseed and protect by mulch any eroded area.
- Supply seeded areas with adequate moisture, but do not water to the extent that it causes runoff.

***Approved as Equivalent***

Ecology has approved products as able to meet the requirements of [BMP C120](#). The products did not pass through the Technology Assessment Protocol – Ecology (TAPE) process. Local jurisdictions may choose not to accept this product approved as equivalent, or may require additional testing prior to consideration for local use. The products are available for review on Ecology’s website at <http://www.ecy.wa.gov/programs/wq/stormwater/newtech/equivalent.html>.

**BMP C121: Mulching**

***Purpose***

Mulching soils provides immediate temporary protection from erosion. Mulch also enhances plant establishment by conserving moisture, holding fertilizer, seed, and topsoil in place, and moderating soil temperatures. There is an enormous variety of mulches that can be used. This section discusses only the most common types of mulch.

***Conditions of Use***

As a temporary cover measure, mulch should be used:

- For less than 30 days on disturbed areas that require cover.
- At all times for seeded areas, especially during the wet season and during the hot summer months.

- During the wet season on slopes steeper than 3H:1V with more than 10 feet of vertical relief.

Mulch may be applied at any time of the year and must be refreshed periodically.

- For seeded areas mulch may be made up of 100 percent: cottonseed meal; fibers made of wood, recycled cellulose, hemp, kenaf; compost; or blends of these. Tackifier shall be plant-based, such as guar or alpha plantago, or chemical-based such as polyacrylamide or polymers. Any mulch or tackifier product used shall be installed per manufacturer’s instructions. Generally, mulches come in 40-50 pound bags. Seed and fertilizer are added at time of application.

***Design and Installation Specifications***

For mulch materials, application rates, and specifications, see [Table 4.1.8](#). Always use a 2-inch minimum mulch thickness; increase the thickness until the ground is 95% covered (i.e. not visible under the mulch layer).

Note: Thickness may be increased for disturbed areas in or near sensitive areas or other areas highly susceptible to erosion.

Where the option of “Compost” is selected, it should be a coarse compost that meets the following size gradations when tested in accordance with the U.S. Composting Council “Test Methods for the Examination of Compost and Composting” (TMECC) Test Method 02.02-B.

Coarse Compost

Minimum Percent passing 3” sieve openings 100%

Minimum Percent passing 1” sieve openings 90%

Minimum Percent passing ¾” sieve openings 70%

Minimum Percent passing ¼” sieve openings 40%

Mulch used within the ordinary high-water mark of surface waters should be selected to minimize potential flotation of organic matter. Composted organic materials have higher specific gravities (densities) than straw, wood, or chipped material. Consult Hydraulic Permit Authority (HPA) for mulch mixes if applicable.

***Maintenance Standards***

- The thickness of the cover must be maintained.
- Any areas that experience erosion shall be remulched and/or protected with a net or blanket. If the erosion problem is drainage related, then the problem shall be fixed and the eroded area remulched.

**Table 4.1.8  
Mulch Standards and Guidelines**

<b>Mulch Material</b>	<b>Quality Standards</b>	<b>Application Rates</b>	<b>Remarks</b>
Straw	Air-dried; free from undesirable seed and coarse material.	2"-3" thick; 5 bales per 1,000 sf or 2-3 tons per acre	Cost-effective protection when applied with adequate thickness. Hand-application generally requires greater thickness than blown straw. The thickness of straw may be reduced by half when used in conjunction with seeding. In windy areas straw must be held in place by crimping, using a tackifier, or covering with netting. Blown straw always has to be held in place with a tackifier as even light winds will blow it away. Straw, however, has several deficiencies that should be considered when selecting mulch materials. It often introduces and/or encourages the propagation of weed species and it has no significant long-term benefits. It should also not be used within the ordinary high-water elevation of surface waters (due to flotation).
Hydromulch	No growth inhibiting factors.	Approx. 25-30 lbs per 1,000 sf or 1,500 - 2,000 lbs per acre	Shall be applied with hydromulcher. Shall not be used without seed and tackifier unless the application rate is at least doubled. Fibers longer than about ¾-1 inch clog hydromulch equipment. Fibers should be kept to less than ¾ inch.
Compost	No visible water or dust during handling. Must be produced per <a href="#">WAC 173-350</a> , Solid Waste Handling Standards, but may have up to 35% biosolids.	2" thick min.; approx. 100 tons per acre (approx. 800 lbs per yard)	More effective control can be obtained by increasing thickness to 3". Excellent mulch for protecting final grades until landscaping because it can be directly seeded or tilled into soil as an amendment. Compost used for mulch has a coarser size gradation than compost used for BMP C125 or BMP T5.13 (see Chapter 5 of Volume V of this manual) It is more stable and practical to use in wet areas and during rainy weather conditions. Do not use near wetlands or near phosphorous impaired water bodies.
Chipped Site Vegetation	Average size shall be several inches. Gradations from fines to 6 inches in length for texture, variation, and interlocking properties.	2" thick min.;	This is a cost-effective way to dispose of debris from clearing and grubbing, and it eliminates the problems associated with burning. Generally, it should not be used on slopes above approx. 10% because of its tendency to be transported by runoff. It is not recommended within 200 feet of surface waters. If seeding is expected shortly after mulch, the decomposition of the chipped vegetation may tie up nutrients important to grass establishment.
Wood-based Mulch or Wood Straw	No visible water or dust during handling. Must be purchased from a supplier with a Solid Waste Handling Permit or one exempt from solid waste regulations.	2" thick min.; approx. 100 tons per acre (approx. 800 lbs. per cubic yard)	This material is often called "hog or hogged fuel." The use of mulch ultimately improves the organic matter in the soil. Special caution is advised regarding the source and composition of wood-based mulches. Its preparation typically does not provide any weed seed control, so evidence of residual vegetation in its composition or known inclusion of weed plants or seeds should be monitored and prevented (or minimized).
Wood Strand Mulch	A blend of loose, long, thin wood pieces derived from native conifer or deciduous trees with high length-to-width ratio.	2" thick min.	Cost-effective protection when applied with adequate thickness. A minimum of 95-percent of the wood strand shall have lengths between 2 and 10-inches, with a width and thickness between 1/16 and ¾-inches. The mulch shall not contain resin, tannin, or other compounds in quantities that would be detrimental to plant life. Sawdust or wood shavings shall not be used as mulch. (WSDOT specification (9-14.4(4)))



## **BMP C122: Nets and Blankets**

### ***Purpose***

Erosion control nets and blankets are intended to prevent erosion and hold seed and mulch in place on steep slopes and in channels so that vegetation can become well established. In addition, some nets and blankets can be used to permanently reinforce turf to protect drainage ways during high flows. Nets (commonly called matting) are strands of material woven into an open, but high-tensile strength net (for example, coconut fiber matting). Blankets are strands of material that are not tightly woven, but instead form a layer of interlocking fibers, typically held together by a biodegradable or photodegradable netting (for example, excelsior or straw blankets). They generally have lower tensile strength than nets, but cover the ground more completely. Coir (coconut fiber) fabric comes as both nets and blankets.

### ***Conditions of Use***

Erosion control nets and blankets should be used:

- To aid permanent vegetated stabilization of slopes 2H:1V or greater and with more than 10 feet of vertical relief.
- For drainage ditches and swales (highly recommended). The application of appropriate netting or blanket to drainage ditches and swales can protect bare soil from channelized runoff while vegetation is established. Nets and blankets also can capture a great deal of sediment due to their open, porous structure. Nets and blankets can be used to permanently stabilize channels and may provide a cost-effective, environmentally preferable alternative to riprap. 100 percent synthetic blankets manufactured for use in ditches may be easily reused as temporary ditch liners.

Disadvantages of blankets include:

- Surface preparation required.
- On slopes steeper than 2.5H:1V, blanket installers may need to be roped and harnessed for safety.
- They cost at least \$4,000-6,000 per acre installed.

Advantages of blankets include:

- Installation without mobilizing special equipment.
- Installation by anyone with minimal training
- Installation in stages or phases as the project progresses.
- Installers can hand place seed and fertilizer as they progress down the slope.
- Installation in any weather.
- There are numerous types of blankets that can be designed with various parameters in mind. Those parameters include: fiber blend, mesh strength, longevity, biodegradability, cost, and availability.

## ***Design and Installation Specifications***

- See [Figure 4.1.3](#) and [Figure 4.1.4](#) for typical orientation and installation of blankets used in channels and as slope protection. Note: these are typical only; all blankets must be installed per manufacturer's installation instructions.
- Installation is critical to the effectiveness of these products. If good ground contact is not achieved, runoff can concentrate under the product, resulting in significant erosion.
- Installation of Blankets on Slopes:
  1. Complete final grade and track walk up and down the slope.
  2. Install hydromulch with seed and fertilizer.
  3. Dig a small trench, approximately 12 inches wide by 6 inches deep along the top of the slope.
  4. Install the leading edge of the blanket into the small trench and staple approximately every 18 inches. NOTE: Staples are metal, "U"-shaped, and a minimum of 6 inches long. Longer staples are used in sandy soils. Biodegradable stakes are also available.
  5. Roll the blanket slowly down the slope as installer walks backwards. NOTE: The blanket rests against the installer's legs. Staples are installed as the blanket is unrolled. It is critical that the proper staple pattern is used for the blanket being installed. The blanket is not to be allowed to roll down the slope on its own as this stretches the blanket making it impossible to maintain soil contact. In addition, no one is allowed to walk on the blanket after it is in place.
  6. If the blanket is not long enough to cover the entire slope length, the trailing edge of the upper blanket should overlap the leading edge of the lower blanket and be stapled. On steeper slopes, this overlap should be installed in a small trench, stapled, and covered with soil.
- With the variety of products available, it is impossible to cover all the details of appropriate use and installation. Therefore, it is critical that the design engineer consult the manufacturer's information and that a site visit takes place in order to ensure that the product specified is appropriate. Information is also available at the following web sites:
  1. WSDOT (Section 3.2.4):  
<http://www.wsdot.wa.gov/NR/rdonlyres/3B41E087-FA86-4717-932D-D7A8556CCD57/0/ErosionTrainingManual.pdf>
  2. Texas Transportation Institute:  
[http://www.txdot.gov/business/doing\\_business/product\\_evaluation/erosion\\_control.htm](http://www.txdot.gov/business/doing_business/product_evaluation/erosion_control.htm)

- Use jute matting in conjunction with mulch ([BMP C121](#)). Excelsior, woven straw blankets and coir (coconut fiber) blankets may be installed without mulch. There are many other types of erosion control nets and blankets on the market that may be appropriate in certain circumstances.
  - In general, most nets (e.g., jute matting) require mulch in order to prevent erosion because they have a fairly open structure. Blankets typically do not require mulch because they usually provide complete protection of the surface.
  - Extremely steep, unstable, wet, or rocky slopes are often appropriate candidates for use of synthetic blankets, as are riverbanks, beaches and other high-energy environments. If synthetic blankets are used, the soil should be hydromulched first.
  - 100-percent biodegradable blankets are available for use in sensitive areas. These organic blankets are usually held together with a paper or fiber mesh and stitching which may last up to a year.
  - Most netting used with blankets is photodegradable, meaning they break down under sunlight (not UV stabilized). However, this process can take months or years even under bright sun. Once vegetation is established, sunlight does not reach the mesh. It is not uncommon to find non-degraded netting still in place several years after installation. This can be a problem if maintenance requires the use of mowers or ditch cleaning equipment. In addition, birds and small animals can become trapped in the netting.
- Maintenance Standards***
- Maintain good contact with the ground. Erosion must not occur beneath the net or blanket.
  - Repair and staple any areas of the net or blanket that are damaged or not in close contact with the ground.
  - Fix and protect eroded areas if erosion occurs due to poorly controlled drainage.

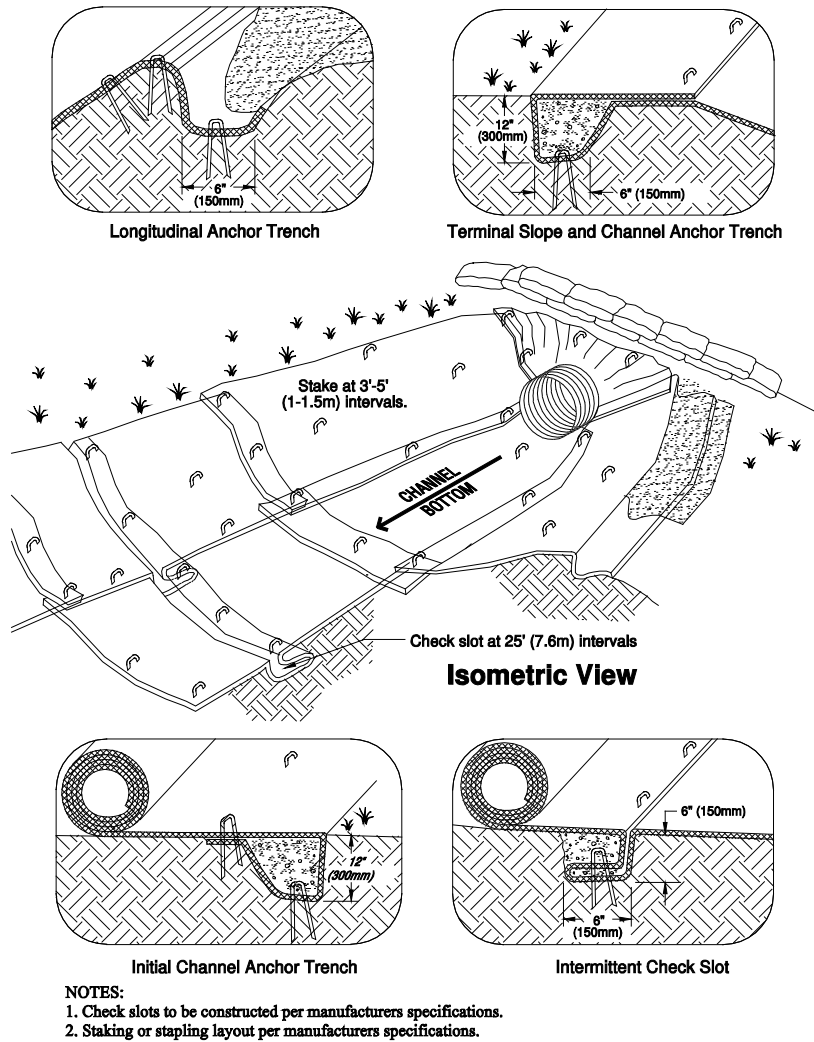

**Figure 4.1.3 – Channel Installation**

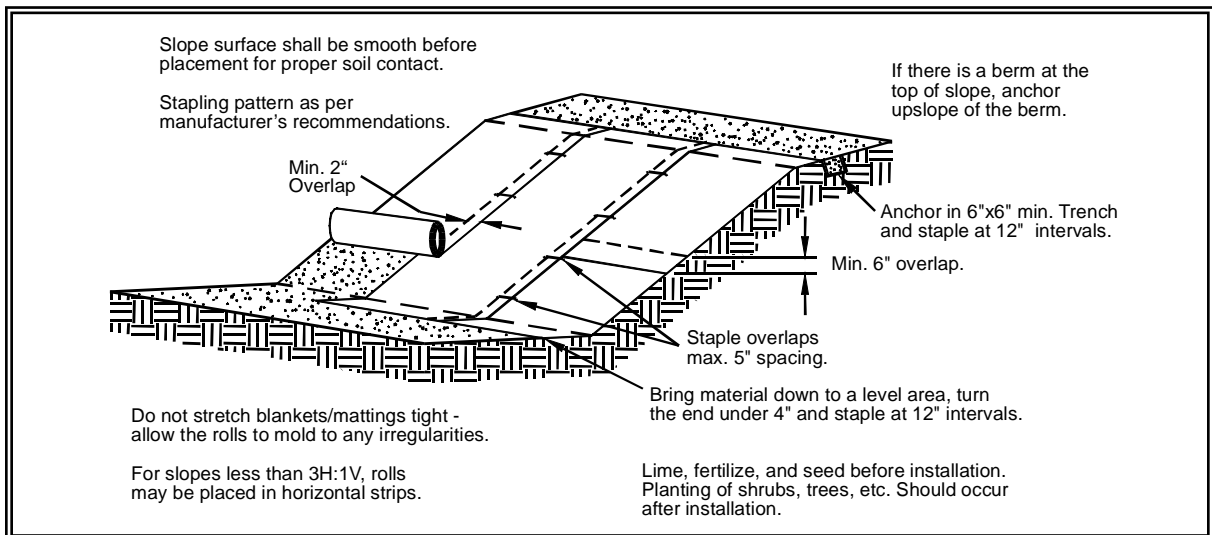

**Figure 4.1.4 – Slope Installation**

## **BMP C123: Plastic Covering**

### ***Purpose***

Plastic covering provides immediate, short-term erosion protection to slopes and disturbed areas.

### ***Conditions of Use***

Plastic covering may be used on disturbed areas that require cover measures for less than 30 days, except as stated below.

- Plastic is particularly useful for protecting cut and fill slopes and stockpiles. Note: The relatively rapid breakdown of most polyethylene sheeting makes it unsuitable for long-term (greater than six months) applications.
- Due to rapid runoff caused by plastic covering, do not use this method upslope of areas that might be adversely impacted by concentrated runoff. Such areas include steep and/or unstable slopes.
- Plastic sheeting may result in increased runoff volumes and velocities, requiring additional on-site measures to counteract the increases. Creating a trough with wattles or other material can convey clean water away from these areas.
- To prevent undercutting, trench and backfill rolled plastic covering products.
- While plastic is inexpensive to purchase, the added cost of installation, maintenance, removal, and disposal make this an expensive material, up to \$1.50-2.00 per square yard.
- Whenever plastic is used to protect slopes install water collection measures at the base of the slope. These measures include plastic-covered berms, channels, and pipes used to convey clean rainwater away from bare soil and disturbed areas. Do not mix clean runoff from a plastic covered slope with dirty runoff from a project.
- Other uses for plastic include:
  1. Temporary ditch liner.
  2. Pond liner in temporary sediment pond.
  3. Liner for bermed temporary fuel storage area if plastic is not reactive to the type of fuel being stored.
  4. Emergency slope protection during heavy rains.
  5. Temporary drainpipe (“elephant trunk”) used to direct water.
- Plastic slope cover must be installed as follows:
  1. Run plastic up and down slope, not across slope.
  2. Plastic may be installed perpendicular to a slope if the slope length is less than 10 feet.
  3. Minimum of 8-inch overlap at seams.

### ***Design and Installation Specifications***

4. On long or wide slopes, or slopes subject to wind, tape all seams.
  5. Place plastic into a small (12-inch wide by 6-inch deep) slot trench at the top of the slope and backfill with soil to keep water from flowing underneath.
  6. Place sand filled burlap or geotextile bags every 3 to 6 feet along seams and tie them together with twine to hold them in place.
  7. Inspect plastic for rips, tears, and open seams regularly and repair immediately. This prevents high velocity runoff from contacting bare soil which causes extreme erosion.
  8. Sandbags may be lowered into place tied to ropes. However, all sandbags must be staked in place.
- Plastic sheeting shall have a minimum thickness of 0.06 millimeters.
  - If erosion at the toe of a slope is likely, a gravel berm, riprap, or other suitable protection shall be installed at the toe of the slope in order to reduce the velocity of runoff.
  - Torn sheets must be replaced and open seams repaired.
  - Completely remove and replace the plastic if it begins to deteriorate due to ultraviolet radiation.
  - Completely remove plastic when no longer needed.
  - Dispose of old tires used to weight down plastic sheeting appropriately.

***Maintenance Standards***

***Approved as Equivalent***

Ecology has approved products as able to meet the requirements of [BMP C123](#). The products did not pass through the Technology Assessment Protocol – Ecology (TAPE) process. Local jurisdictions may choose not to accept this product approved as equivalent, or may require additional testing prior to consideration for local use. The products are available for review on Ecology’s website at <http://www.ecy.wa.gov/programs/wq/stormwater/newtech/equivalent.html>

**BMP C124: Sodding**

***Purpose***

The purpose of sodding is to establish permanent turf for immediate erosion protection and to stabilize drainage ways where concentrated overland flow will occur.

***Conditions of Use***

Sodding may be used in the following areas:

- Disturbed areas that require short-term or long-term cover.
- Disturbed areas that require immediate vegetative cover.
- All waterways that require vegetative lining. Waterways may also be seeded rather than sodded, and protected with a net or blanket.

***Design and  
Installation  
Specifications***

Sod shall be free of weeds, of uniform thickness (approximately 1-inch thick), and shall have a dense root mat for mechanical strength.

The following steps are recommended for sod installation:

- Shape and smooth the surface to final grade in accordance with the approved grading plan. The swale needs to be overexcavated 4 to 6 inches below design elevation to allow room for placing soil amendment and sod.
- Amend 4 inches (minimum) of compost into the top 8 inches of the soil if the organic content of the soil is less than ten percent or the permeability is less than 0.6 inches per hour. See <http://www.ecy.wa.gov/programs/swfa/organics/soil.html> for further information.
- Fertilize according to the supplier's recommendations.
- Work lime and fertilizer 1 to 2 inches into the soil, and smooth the surface.
- Lay strips of sod beginning at the lowest area to be sodded and perpendicular to the direction of water flow. Wedge strips securely into place. Square the ends of each strip to provide for a close, tight fit. Stagger joints at least 12 inches. Staple on slopes steeper than 3H:1V. Staple the upstream edge of each sod strip.
- Roll the sodded area and irrigate.
- When sodding is carried out in alternating strips or other patterns, seed the areas between the sod immediately after sodding.

***Maintenance  
Standards***

If the grass is unhealthy, the cause shall be determined and appropriate action taken to reestablish a healthy groundcover. If it is impossible to establish a healthy groundcover due to frequent saturation, instability, or some other cause, the sod shall be removed, the area seeded with an appropriate mix, and protected with a net or blanket.

**BMP C125: Topsoiling / Composting**

***Purpose***

Topsoiling and composting provide a suitable growth medium for final site stabilization with vegetation. While not a permanent cover practice in itself, topsoiling and composting are an integral component of providing permanent cover in those areas where there is an unsuitable soil surface for plant growth. Use this BMP in conjunction with other BMPs such as seeding, mulching, or sodding. Note that this BMP is functionally the same as BMP T5.13 (see Chapter 5 of Volume V of this manual) which is required for all disturbed areas that will be developed as lawn or landscaped areas at the completed project site.

Native soils and disturbed soils that have been organically amended not only retain much more stormwater, but they also serve as effective

biofilters for urban pollutants and, by supporting more vigorous plant growth, reduce the water, fertilizer and pesticides needed to support installed landscapes. Topsoil does not include any subsoils but only the material from the top several inches including organic debris.

***Conditions of Use***

- Permanent landscaped areas shall contain healthy topsoil that reduces the need for fertilizers, improves overall topsoil quality, provides for better vegetal health and vitality, improves hydrologic characteristics, and reduces the need for irrigation.
- Leave native soils and the duff layer undisturbed to the maximum extent practicable. Stripping of existing, properly functioning soil system and vegetation for the purpose of topsoiling during construction is not acceptable. Preserve existing soil systems in undisturbed and uncompacted conditions if functioning properly.
- Areas that already have good topsoil, such as undisturbed areas, do not require soil amendments.
- Restore, to the maximum extent practical, native soils disturbed during clearing and grading to a condition equal to or better than the original site condition's moisture-holding capacity. Use on-site native topsoil, incorporate amendments into on-site soil, or import blended topsoil to meet this requirement.
- Topsoiling is a required procedure when establishing vegetation on shallow soils, and soils of critically low pH (high acid) levels.
- Beware of where the topsoil comes from, and what vegetation was on site before disturbance, invasive plant seeds may be included and could cause problems for establishing native plants, landscaped areas, or grasses.
- Topsoil from the site will contain mycorrhizal bacteria that are necessary for healthy root growth and nutrient transfer. These native mycorrhiza are acclimated to the site and will provide optimum conditions for establishing grasses. Use commercially available mycorrhiza products when using off-site topsoil.

***Design and Installation Specifications***

Meet the following requirements for disturbed areas that will be developed as lawn or landscaped areas at the completed project site:

- Maximize the depth of the topsoil wherever possible to provide the maximum possible infiltration capacity and beneficial growth medium. Topsoil shall have:
  - A minimum depth of 8-inches. Scarify subsoils below the topsoil layer at least 4-inches with some incorporation of the upper material to avoid stratified layers, where feasible. Ripping or restructuring the subgrade may also provide additional benefits regarding the overall infiltration and interflow dynamics of the soil system.



- A minimum organic content of 10% dry weight in planting beds, and 5% organic matter content in turf areas. Incorporate organic amendments to a minimum 8-inch depth except where tree roots or other natural features limit the depth of incorporation.
- A pH between 6.0 and 8.0 or matching the pH of the undisturbed soil.
- If blended topsoil is imported, then fines should be limited to 25 percent passing through a 200 sieve.
- Mulch planting beds with 2 inches of organic material
- Accomplish the required organic content, depth, and pH by returning native topsoil to the site, importing topsoil of sufficient organic content, and/or incorporating organic amendments. When using the option of incorporating amendments to meet the organic content requirement, use compost that meets the compost specification for Bioretention (See BMP T7.30 in Chapter 7 of Volume V of this manual), with the exception that the compost may have up to 35% biosolids or manure.
- Sections three through seven of the document entitled, *Guidelines and Resources for Implementing Soil Quality and Depth BMP T5.13 in WDOE Stormwater Management Manual for Western Washington*, provides useful guidance for implementing whichever option is chosen. It includes guidance for pre-approved default strategies and guidance for custom strategies. Check with your local jurisdiction concerning its acceptance of this guidance. It is available through the organization, Soils for Salmon. As of this printing the document may be found at:  
[http://www.soilsforsalmon.org/pdf/Soil\\_BMP\\_Manual.pdf](http://www.soilsforsalmon.org/pdf/Soil_BMP_Manual.pdf).
- The final composition and construction of the soil system will result in a natural selection or favoring of certain plant species over time. For example, incorporation of topsoil may favor grasses, while layering with mildly acidic, high-carbon amendments may favor more woody vegetation.
- Allow sufficient time in scheduling for topsoil spreading prior to seeding, sodding, or planting.
- Take care when applying top soil to subsoils with contrasting textures. Sandy topsoil over clayey subsoil is a particularly poor combination, as water creeps along the junction between the soil layers and causes the topsoil to slough. If topsoil and subsoil are not properly bonded, water will not infiltrate the soil profile evenly and it will be difficult to establish vegetation. The best method to prevent a lack of bonding is to actually work the topsoil into the layer below for a depth of at least 6 inches.

- Field exploration of the site shall be made to determine if there is surface soil of sufficient quantity and quality to justify stripping. Topsoil shall be friable and loamy (loam, sandy loam, silt loam, sandy clay loam, and clay loam). Avoid areas of natural ground water recharge.
- Stripping shall be confined to the immediate construction area. A 4-inch to 6-inch stripping depth is common, but depth may vary depending on the particular soil. All surface runoff control structures shall be in place prior to stripping.
- Do not place topsoil while in a frozen or muddy condition, when the subgrade is excessively wet, or when conditions exist that may otherwise be detrimental to proper grading or proposed sodding or seeding.
- In any areas requiring grading remove and stockpile the duff layer and topsoil on site in a designated, controlled area, not adjacent to public resources and critical areas. Stockpiled topsoil is to be reapplied to other portions of the site where feasible.
- Locate the topsoil stockpile so that it meets specifications and does not interfere with work on the site. It may be possible to locate more than one pile in proximity to areas where topsoil will be used.

Stockpiling of topsoil shall occur in the following manner:

- Side slopes of the stockpile shall not exceed 2H:1V.
- Between October 1 and April 30:
  - An interceptor dike with gravel outlet and silt fence shall surround all topsoil.
  - Within 2 days complete erosion control seeding, or covering stockpiles with clear plastic, or other mulching materials.
- Between May 1 and September 30:
  - An interceptor dike with gravel outlet and silt fence shall surround all topsoil if the stockpile will remain in place for a longer period of time than active construction grading.
  - Within 7 days complete erosion control seeding, or covering stockpiles with clear plastic, or other mulching materials.
- When native topsoil is to be stockpiled and reused the following should apply to ensure that the mycorrhizal bacterial, earthworms, and other beneficial organisms will not be destroyed:
  1. Re-install topsoil within 4 to 6 weeks.
  2. Do not allow the saturation of topsoil with water.
  3. Do not use plastic covering.

***Maintenance Standards***

- Inspect stockpiles regularly, especially after large storm events. Stabilize any areas that have eroded.
- Establish soil quality and depth toward the end of construction and once established, protect from compaction, such as from large machinery use, and from erosion.
- Plant and mulch soil after installation.
- Leave plant debris or its equivalent on the soil surface to replenish organic matter.
- Reduce and adjust, where possible, the use of irrigation, fertilizers, herbicides and pesticides, rather than continuing to implement formerly established practices.

**BMP C126: Polyacrylamide (PAM) for Soil Erosion Protection**

***Purpose***

Polyacrylamide (PAM) is used on construction sites to prevent soil erosion.

Applying PAM to bare soil in advance of a rain event significantly reduces erosion and controls sediment in two ways. First, PAM increases the soil's available pore volume, thus increasing infiltration through flocculation and reducing the quantity of stormwater runoff. Second, it increases flocculation of suspended particles and aids in their deposition, thus reducing stormwater runoff turbidity and improving water quality.

***Conditions of Use***

PAM shall not be directly applied to water or allowed to enter a water body.

In areas that drain to a sediment pond, PAM can be applied to bare soil under the following conditions:

- During rough grading operations.
- In Staging areas.
- Balanced cut and fill earthwork.
- Haul roads prior to placement of crushed rock surfacing.
- Compacted soil roadbase.
- Stockpiles.
- After final grade and before paving or final seeding and planting.
- Pit sites.
- Sites having a winter shut down. In the case of winter shut down, or where soil will remain unworked for several months, PAM should be used together with mulch.

***Design and  
Installation  
Specifications***

PAM may be applied with water in dissolved form. The preferred application method is the dissolved form.

PAM is to be applied at a maximum rate of 2/3 pound PAM per 1,000 gallons water (80 mg/L) per 1 acre of bare soil. [Table 4.1.9](#) can be used to determine the PAM and water application rate for a disturbed soil area. Higher concentrations of PAM **do not** provide any additional effectiveness.

<b>Table 4.1.9 PAM and Water Application Rates</b>		
<b>Disturbed Area (ac)</b>	<b>PAM (lbs)</b>	<b>Water (gal)</b>
0.50	0.33	500
1.00	0.66	1,000
1.50	1.00	1,500
2.00	1.32	2,000
2.50	1.65	2,500
3.00	2.00	3,000
3.50	2.33	3,500
4.00	2.65	4,000
4.50	3.00	4,500
5.00	3.33	5,000

The Preferred Method:

- Pre-measure the area where PAM is to be applied and calculate the amount of product and water necessary to provide coverage at the specified application rate (2/3 pound PAM/1000 gallons/acre).
- PAM has infinite solubility in water, but dissolves very slowly. Dissolve pre-measured dry granular PAM with a known quantity of clean water in a bucket several hours or overnight. Mechanical mixing will help dissolve the PAM. Always add PAM to water - not water to PAM.
- Pre-fill the water truck about 1/8 full with water. The water does not have to be potable, but it must have relatively low turbidity – in the range of 20 NTU or less.
- Add PAM /Water mixture to the truck
- Completely fill the water truck to specified volume.
- Spray PAM/Water mixture onto dry soil until the soil surface is uniformly and completely wetted.

An Alternate Method:

PAM may also be applied as a powder at the rate of 5 lbs. per acre. This must be applied on a day that is dry. For areas less than 5-10 acres, a hand-held “organ grinder” fertilizer spreader set to the smallest setting will work. Tractor-mounted spreaders will work for larger areas.

The following shall be used for application of powdered PAM:

- Powdered PAM shall be used in conjunction with other BMPs and not in place of other BMPs.
- Do not use PAM on a slope that flows directly into a stream or wetland. The stormwater runoff shall pass through a sediment control BMP prior to discharging to surface waters.
- Do not add PAM to water discharging from site.
- When the total drainage area is greater than or equal to 5 acres, PAM treated areas shall drain to a sediment pond.
- Areas less than 5 acres shall drain to sediment control BMPs, such as a minimum of 3 check dams per acre. The total number of check dams used shall be maximized to achieve the greatest amount of settlement of sediment prior to discharging from the site. Each check dam shall be spaced evenly in the drainage channel through which stormwater flows are discharged off-site.
- On all sites, the use of silt fence shall be maximized to limit the discharges of sediment from the site.
- All areas not being actively worked shall be covered and protected from rainfall. PAM shall not be the only cover BMP used.
- PAM can be applied to wet soil, but dry soil is preferred due to less sediment loss.
- PAM will work when applied to saturated soil but is not as effective as applications to dry or damp soil.
- Keep the granular PAM supply out of the sun. Granular PAM loses its effectiveness in three months after exposure to sunlight and air.
- Proper application and re-application plans are necessary to ensure total effectiveness of PAM usage.
- PAM, combined with water, is very slippery and can be a safety hazard. Care must be taken to prevent spills of PAM powder onto paved surfaces. During an application of PAM, prevent over-spray from reaching pavement as pavement will become slippery. If PAM powder gets on skin or clothing, wipe it off with a rough towel rather than washing with water-this only makes cleanup messier and take longer.
- Some PAMs are more toxic and carcinogenic than others. Only the most environmentally safe PAM products should be used.

The specific PAM copolymer formulation must be anionic. **Cationic PAM shall not be used in any application because of known aquatic toxicity problems.** Only the highest drinking water grade PAM, certified for compliance with ANSI/NSF Standard 60 for

drinking water treatment, will be used for soil applications. Recent media attention and high interest in PAM has resulted in some entrepreneurial exploitation of the term "polymer." All PAM are polymers, but not all polymers are PAM, and not all PAM products comply with ANSI/NSF Standard 60. PAM use shall be reviewed and approved by the local permitting authority.

- PAM designated for these uses should be "water soluble" or "linear" or "non-crosslinked". Cross-linked or water absorbent PAM, polymerized in highly acidic (pH<2) conditions, are used to maintain soil moisture content.
- The PAM anionic charge density may vary from 2-30 percent; a value of 18 percent is typical. Studies conducted by the United States Department of Agriculture (USDA)/ARS demonstrated that soil stabilization was optimized by using very high molecular weight (12-15 mg/mole), highly anionic (>20% hydrolysis) PAM.
- PAM tackifiers are available and being used in place of guar and alpha plantago. Typically, PAM tackifiers should be used at a rate of no more than 0.5-1 lb. per 1000 gallons of water in a hydromulch machine. Some tackifier product instructions say to use at a rate of 3 –5 lbs. per acre, which can be too much. In addition, pump problems can occur at higher rates due to increased viscosity.

### ***Maintenance Standards***

- PAM may be reapplied on actively worked areas after a 48-hour period.
- Reapplication is not required unless PAM treated soil is disturbed or unless turbidity levels show the need for an additional application. If PAM treated soil is left undisturbed a reapplication may be necessary after two months. More PAM applications may be required for steep slopes, silty and clayey soils (USDA Classification Type "C" and "D" soils), long grades, and high precipitation areas. When PAM is applied first to bare soil and then covered with straw, a reapplication may not be necessary for several months.
- Loss of sediment and PAM may be a basis for penalties per [RCW 90.48.080](#).

### **BMP C130: Surface Roughening**

#### ***Purpose***

Surface roughening aids in the establishment of vegetative cover, reduces runoff velocity, increases infiltration, and provides for sediment trapping through the provision of a rough soil surface. Horizontal depressions are created by operating a tiller or other suitable equipment on the contour or by leaving slopes in a roughened condition by not fine grading them.

Use this BMP in conjunction with other BMPs such as seeding, mulching, or sodding.

***Conditions for Use***

- All slopes steeper than 3H:1V and greater than 5 vertical feet require surface roughening to a depth of 2 to 4 inches prior to seeding.
- Areas that will not be stabilized immediately may be roughened to reduce runoff velocity until seeding takes place.
- Slopes with a stable rock face do not require roughening.
- Slopes where mowing is planned should not be excessively roughened.

***Design and Installation Specifications***

There are different methods for achieving a roughened soil surface on a slope, and the selection of an appropriate method depends upon the type of slope. Roughening methods include stair-step grading, grooving, contour furrows, and tracking. See [Figure 4.1.5](#) for tracking and contour furrows. Factors to be considered in choosing a method are slope steepness, mowing requirements, and whether the slope is formed by cutting or filling.

- Disturbed areas that will not require mowing may be stair-step graded, grooved, or left rough after filling.
- Stair-step grading is particularly appropriate in soils containing large amounts of soft rock. Each "step" catches material that sloughs from above, and provides a level site where vegetation can become established. Stairs should be wide enough to work with standard earth moving equipment. Stair steps must be on contour or gullies will form on the slope.
- Areas that will be mowed (these areas should have slopes less steep than 3H:1V) may have small furrows left by disking, harrowing, raking, or seed-planting machinery operated on the contour.
- Graded areas with slopes steeper than 3H:1V but less than 2H:1V should be roughened before seeding. This can be accomplished in a variety of ways, including "track walking," or driving a crawler tractor up and down the slope, leaving a pattern of cleat imprints parallel to slope contours.
- Tracking is done by operating equipment up and down the slope to leave horizontal depressions in the soil.

***Maintenance Standards***

- Areas that are graded in this manner should be seeded as quickly as possible.
- Regular inspections should be made of the area. If rills appear, they should be re-graded and re-seeded immediately.

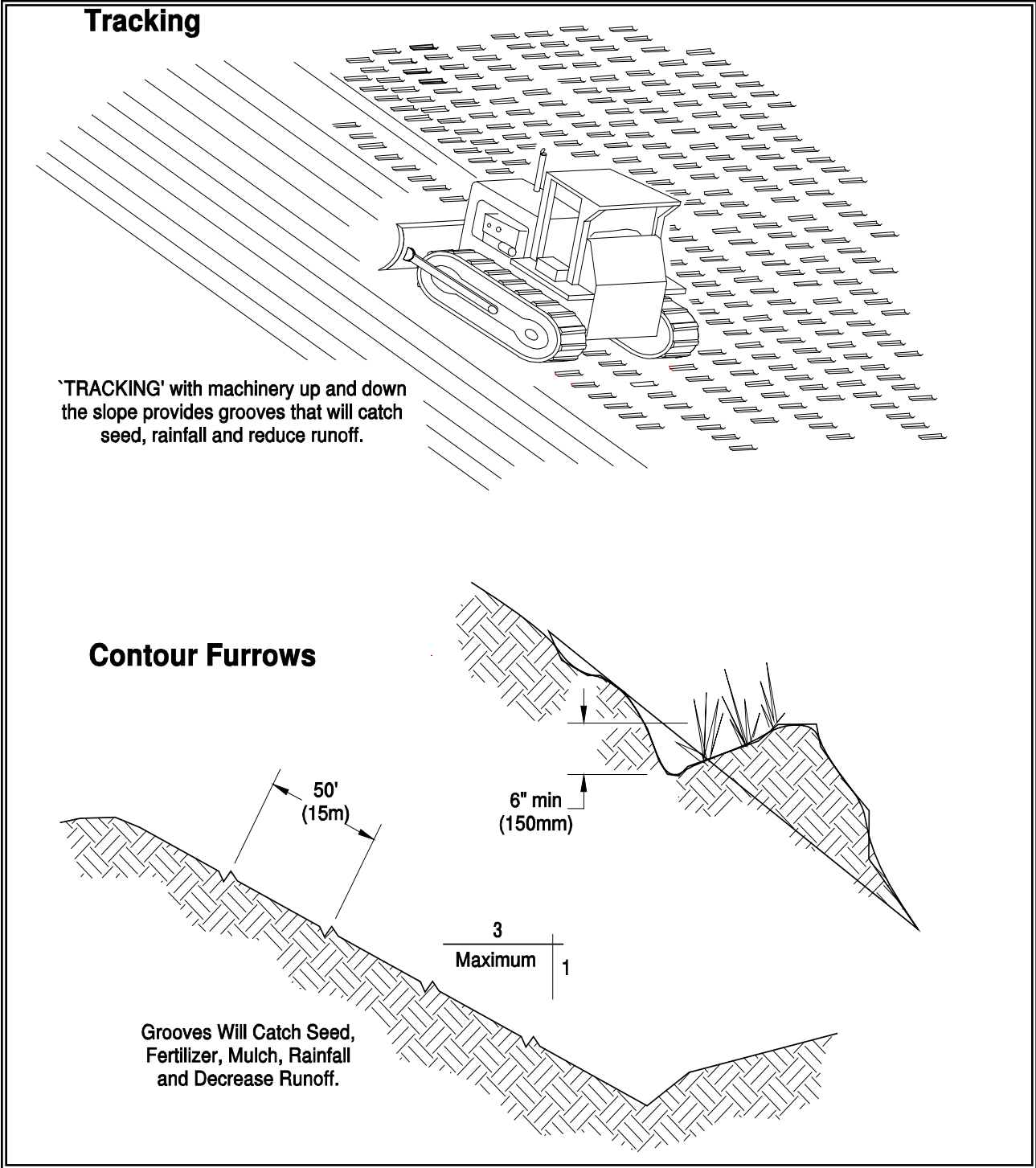

Figure 4.1.5 – Surface Roughening by Tracking and Contour Furrows



## BMP C131: Gradient Terraces

### *Purpose*

Gradient terraces reduce erosion damage by intercepting surface runoff and conducting it to a stable outlet at a non-erosive velocity.

### *Conditions of Use*

- Gradient terraces normally are limited to denuded land having a water erosion problem. They should not be constructed on deep sands or on soils that are too stony, steep, or shallow to permit practical and economical installation and maintenance. Gradient terraces may be used only where suitable outlets are or will be made available. See [Figure 4.1.6](#) for gradient terraces.

### *Design and Installation Specifications*

- The maximum vertical spacing of gradient terraces should be determined by the following method:

$$VI = (0.8)s + y$$

Where: VI = vertical interval in feet

s = land rise per 100 feet, expressed in feet

y = a soil and cover variable with values from 1.0 to 4.0

Values of “y” are influenced by soil erodibility and cover practices. The lower values are applicable to erosive soils where little to no residue is left on the surface. The higher value is applicable only to erosion-resistant soils where a large amount of residue (1½ tons of straw/acre equivalent) is on the surface.

- The minimum constructed cross-section should meet the design dimensions.
- The top of the constructed ridge should not be lower at any point than the design elevation plus the specified overfill for settlement. The opening at the outlet end of the terrace should have a cross section equal to that specified for the terrace channel.
- Channel grades may be either uniform or variable with a maximum grade of 0.6 feet per 100 feet length (0.6%). For short distances, terrace grades may be increased to improve alignment. The channel velocity should not exceed that which is nonerosive for the soil type.
- All gradient terraces should have adequate outlets. Such an outlet may be a grassed waterway, vegetated area, or tile outlet. In all cases the outlet must convey runoff from the terrace or terrace system to a point where the outflow will not cause damage. Vegetative cover should be used in the outlet channel.
- The design elevation of the water surface of the terrace should not be lower than the design elevation of the water surface in the outlet at their junction, when both are operating at design flow.

- Vertical spacing determined by the above methods may be increased as much as 0.5 feet or 10 percent, whichever is greater, to provide better alignment or location, to avoid obstacles, to adjust for equipment size, or to reach a satisfactory outlet. The drainage area above the terrace should not exceed the area that would be drained by a terrace with normal spacing.
  - The terrace should have enough capacity to handle the peak runoff expected from a 2-year, 24-hour design storm without overtopping.
  - The terrace cross-section should be proportioned to fit the land slope. The ridge height should include a reasonable settlement factor. The ridge should have a minimum top width of 3 feet at the design height. The minimum cross-sectional area of the terrace channel should be 8 square feet for land slopes of 5 percent or less, 7 square feet for slopes from 5 to 8 percent, and 6 square feet for slopes steeper than 8 percent. The terrace can be constructed wide enough to be maintained using a small vehicle.
- Maintenance Standards**
- Maintenance should be performed as needed. Terraces should be inspected regularly; at least once a year, and after large storm events.

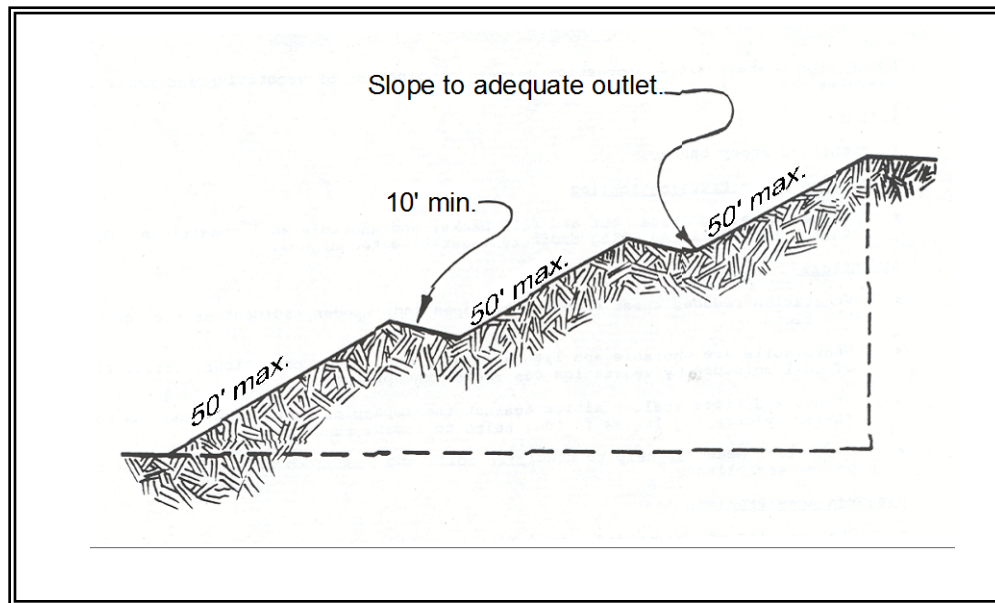

**Figure 4.1.6 – Gradient Terraces**

## **BMP C140: Dust Control**

### ***Purpose***

Dust control prevents wind transport of dust from disturbed soil surfaces onto roadways, drainage ways, and surface waters.

### ***Conditions of Use***

- In areas (including roadways) subject to surface and air movement of dust where on-site and off-site impacts to roadways, drainage ways, or surface waters are likely.

### ***Design and Installation Specifications***

- Vegetate or mulch areas that will not receive vehicle traffic. In areas where planting, mulching, or paving is impractical, apply gravel or landscaping rock.
- Limit dust generation by clearing only those areas where immediate activity will take place, leaving the remaining area(s) in the original condition. Maintain the original ground cover as long as practical.
- Construct natural or artificial windbreaks or windscreens. These may be designed as enclosures for small dust sources.
- Sprinkle the site with water until surface is wet. Repeat as needed. To prevent carryout of mud onto street, refer to Stabilized Construction Entrance ([BMP C105](#)).
- Irrigation water can be used for dust control. Irrigation systems should be installed as a first step on sites where dust control is a concern.
- Spray exposed soil areas with a dust palliative, following the manufacturer's instructions and cautions regarding handling and application. Used oil is prohibited from use as a dust suppressant. Local governments may approve other dust palliatives such as calcium chloride or PAM.
- PAM ([BMP C126](#)) added to water at a rate of 0.5 lbs. per 1,000 gallons of water per acre and applied from a water truck is more effective than water alone. This is due to increased infiltration of water into the soil and reduced evaporation. In addition, small soil particles are bonded together and are not as easily transported by wind. Adding PAM may actually reduce the quantity of water needed for dust control. Use of PAM could be a cost-effective dust control method.

Techniques that can be used for unpaved roads and lots include:

- Lower speed limits. High vehicle speed increases the amount of dust stirred up from unpaved roads and lots.
- Upgrade the road surface strength by improving particle size, shape, and mineral types that make up the surface and base materials.
- Add surface gravel to reduce the source of dust emission. Limit the amount of fine particles (those smaller than .075 mm) to 10 to 20 percent.

- Use geotextile fabrics to increase the strength of new roads or roads undergoing reconstruction.
- Encourage the use of alternate, paved routes, if available.
- Restrict use of paved roadways by tracked vehicles and heavy trucks to prevent damage to road surface and base.
- Apply chemical dust suppressants using the admix method, blending the product with the top few inches of surface material. Suppressants may also be applied as surface treatments.
- Pave unpaved permanent roads and other trafficked areas.
- Use vacuum street sweepers.
- Remove mud and other dirt promptly so it does not dry and then turn into dust.
- Limit dust-causing work on windy days.
- Contact your local Air Pollution Control Authority for guidance and training on other dust control measures. Compliance with the local Air Pollution Control Authority constitutes compliance with this BMP.

***Maintenance Standards***

Respray area as necessary to keep dust to a minimum.

**BMP C150: Materials on Hand**

***Purpose***

Keep quantities of erosion prevention and sediment control materials on the project site at all times to be used for regular maintenance and emergency situations such as unexpected heavy summer rains. Having these materials on-site reduces the time needed to implement BMPs when inspections indicate that existing BMPs are not meeting the Construction SWPPP requirements. In addition, contractors can save money by buying some materials in bulk and storing them at their office or yard.

***Conditions of Use***

- Construction projects of any size or type can benefit from having materials on hand. A small commercial development project could have a roll of plastic and some gravel available for immediate protection of bare soil and temporary berm construction. A large earthwork project, such as highway construction, might have several tons of straw, several rolls of plastic, flexible pipe, sandbags, geotextile fabric and steel “T” posts.
- Materials are stockpiled and readily available before any site clearing, grubbing, or earthwork begins. A large contractor or developer could keep a stockpile of materials that are available for use on several projects.
- If storage space at the project site is at a premium, the contractor could maintain the materials at their office or yard. The office or yard must be less than an hour from the project site.

***Design and Installation Specifications***

Depending on project type, size, complexity, and length, materials and quantities will vary. A good minimum list of items that will cover numerous situations includes:

<b>Material</b>
Clear Plastic, 6 mil
Drainpipe, 6 or 8 inch diameter
Sandbags, filled
Straw Bales for mulching,
Quarry Spalls
Washed Gravel
Geotextile Fabric
Catch Basin Inserts
Steel "T" Posts
Silt fence material
Straw Wattles

***Maintenance Standards***

- All materials with the exception of the quarry spalls, steel "T" posts, and gravel should be kept covered and out of both sun and rain.
- Re-stock materials used as needed.

**BMP C151: Concrete Handling**

***Purpose***

Concrete work can generate process water and slurry that contain fine particles and high pH, both of which can violate water quality standards in the receiving water. Concrete spillage or concrete discharge to surface waters of the State is prohibited. Use this BMP to minimize and eliminate concrete, concrete process water, and concrete slurry from entering waters of the state.

***Conditions of Use***

Any time concrete is used, utilize these management practices. Concrete construction projects include, but are not limited to, the following:

- Curbs
- Sidewalks
- Roads
- Bridges
- Foundations
- Floors
- Runways

***Design and Installation***

- Assure that washout of concrete trucks, chutes, pumps, and internals is performed at an approved off-site location or in designated concrete

## ***Specifications***

washout areas. Do not wash out concrete trucks onto the ground, or into storm drains, open ditches, streets, or streams. Refer to [BMP C154](#) for information on concrete washout areas.

- Return unused concrete remaining in the truck and pump to the originating batch plant for recycling. Do not dump excess concrete on site, except in designated concrete washout areas.
- Wash off hand tools including, but not limited to, screeds, shovels, rakes, floats, and trowels into formed areas only.
- Wash equipment difficult to move, such as concrete pavers in areas that do not directly drain to natural or constructed stormwater conveyances.
- Do not allow washdown from areas, such as concrete aggregate driveways, to drain directly to natural or constructed stormwater conveyances.
- Contain washwater and leftover product in a lined container when no formed areas are available. Dispose of contained concrete in a manner that does not violate ground water or surface water quality standards.
- Always use forms or solid barriers for concrete pours, such as pilings, within 15-feet of surface waters.
- Refer to [BMPs C252](#) and [C253](#) for pH adjustment requirements.
- Refer to the Construction Stormwater General Permit for pH monitoring requirements if the project involves one of the following activities:
  - Significant concrete work (greater than 1,000 cubic yards poured concrete or recycled concrete used over the life of a project).
  - The use of engineered soils amended with (but not limited to) Portland cement-treated base, cement kiln dust or fly ash.
  - Discharging stormwater to segments of water bodies on the 303(d) list (Category 5) for high pH.

## ***Maintenance Standards***

Check containers for holes in the liner daily during concrete pours and repair the same day.

## **BMP C152: Sawcutting and Surfacing Pollution Prevention**

***Purpose*** Sawcutting and surfacing operations generate slurry and process water that contains fine particles and high pH (concrete cutting), both of which can violate the water quality standards in the receiving water. Concrete spillage or concrete discharge to surface waters of the State is prohibited. Use this BMP to minimize and eliminate process water and slurry created through sawcutting or surfacing from entering waters of the State.

***Conditions of Use*** Utilize these management practices anytime sawcutting or surfacing operations take place. Sawcutting and surfacing operations include, but are not limited to, the following:

- Sawing
- Coring
- Grinding
- Roughening
- Hydro-demolition
- Bridge and road surfacing
- Vacuum slurry and cuttings during cutting and surfacing operations.
- Slurry and cuttings shall not remain on permanent concrete or asphalt pavement overnight.
- Slurry and cuttings shall not drain to any natural or constructed drainage conveyance including stormwater systems. This may require temporarily blocking catch basins.
- Dispose of collected slurry and cuttings in a manner that does not violate ground water or surface water quality standards.
- Do not allow process water generated during hydro-demolition, surface roughening or similar operations to drain to any natural or constructed drainage conveyance including stormwater systems. Dispose process water in a manner that does not violate ground water or surface water quality standards.
- Handle and dispose cleaning waste material and demolition debris in a manner that does not cause contamination of water. Dispose of sweeping material from a pick-up sweeper at an appropriate disposal site.

***Maintenance Standards*** Continually monitor operations to determine whether slurry, cuttings, or process water could enter waters of the state. If inspections show that a violation of water quality standards could occur, stop operations and immediately implement preventive measures such as berms, barriers, secondary containment, and vacuum trucks.

## **BMP C153: Material Delivery, Storage and Containment**

<i>Purpose</i>	Prevent, reduce, or eliminate the discharge of pollutants to the stormwater system or watercourses from material delivery and storage. Minimize the storage of hazardous materials on-site, store materials in a designated area, and install secondary containment.
<i>Conditions of Use</i>	<p><b>These procedures are suitable for use at all construction sites with delivery and storage of the following materials:</b></p> <ul style="list-style-type: none"><li>• Petroleum products such as fuel, oil and grease</li><li>• Soil stabilizers and binders (e.g., Polyacrylamide)</li><li>• Fertilizers, pesticides and herbicides</li><li>• Detergents</li><li>• Asphalt and concrete compounds</li><li>• Hazardous chemicals such as acids, lime, adhesives, paints, solvents, and curing compounds</li><li>• Any other material that may be detrimental if released to the environment</li></ul>
<i>Design and Installation Specifications</i>	<p><b>The following steps should be taken to minimize risk:</b></p> <ul style="list-style-type: none"><li>• Temporary storage area should be located away from vehicular traffic, near the construction entrance(s), and away from waterways or storm drains.</li><li>• Material Safety Data Sheets (MSDS) should be supplied for all materials stored. Chemicals should be kept in their original labeled containers.</li><li>• Hazardous material storage on-site should be minimized.</li><li>• Hazardous materials should be handled as infrequently as possible.</li><li>• During the wet weather season (Oct 1 – April 30), consider storing materials in a covered area.</li><li>• Materials should be stored in secondary containments, such as earthen dike, horse trough, or even a children’s wading pool for non-reactive materials such as detergents, oil, grease, and paints. Small amounts of material may be secondarily contained in “bus boy” trays or concrete mixing trays.</li><li>• Do not store chemicals, drums, or bagged materials directly on the ground. Place these items on a pallet and, when possible, and within secondary containment.</li><li>• If drums must be kept uncovered, store them at a slight angle to reduce ponding of rainwater on the lids to reduce corrosion. Domed plastic covers are inexpensive and snap to the top of drums, preventing water from collecting.</li></ul>



### **Material Storage Areas and Secondary Containment Practices:**

- Liquids, petroleum products, and substances listed in 40 CFR Parts 110, 117, or 302 shall be stored in approved containers and drums and shall not be overfilled. Containers and drums shall be stored in temporary secondary containment facilities.
- Temporary secondary containment facilities shall provide for a spill containment volume able to contain 10% of the total enclosed container volume of all containers, or 110% of the capacity of the largest container within its boundary, whichever is greater.
- Secondary containment facilities shall be impervious to the materials stored therein for a minimum contact time of 72 hours.
- Secondary containment facilities shall be maintained free of accumulated rainwater and spills. In the event of spills or leaks, accumulated rainwater and spills shall be collected and placed into drums. These liquids shall be handled as hazardous waste unless testing determines them to be non-hazardous.
- Sufficient separation should be provided between stored containers to allow for spill cleanup and emergency response access.
- During the wet weather season (Oct 1 – April 30), each secondary containment facility shall be covered during non-working days, prior to and during rain events.
- Keep material storage areas clean, organized and equipped with an ample supply of appropriate spill clean-up material (spill kit).
- The spill kit should include, at a minimum:
  - 1-Water Resistant Nylon Bag
  - 3-Oil Absorbent Socks 3”x 4’
  - 2-Oil Absorbent Socks 3”x 10’
  - 12-Oil Absorbent Pads 17”x19”
  - 1-Pair Splash Resistant Goggles
  - 3-Pair Nitrile Gloves
  - 10-Disposable Bags with Ties
  - Instructions

## **BMP C154: Concrete Washout Area**

***Purpose*** Prevent or reduce the discharge of pollutants to stormwater from concrete waste by conducting washout off-site, or performing on-site washout in a designated area to prevent pollutants from entering surface waters or ground water.

***Conditions of Use*** Concrete washout area best management practices are implemented on construction projects where:

- Concrete is used as a construction material
- It is not possible to dispose of all concrete wastewater and washout off-site (ready mix plant, etc.).
- Concrete trucks, pumpers, or other concrete coated equipment are washed on-site.
- Note: If less than 10 concrete trucks or pumpers need to be washed out on-site, the washwater may be disposed of in a formed area awaiting concrete or an upland disposal site where it will not contaminate surface or ground water. The upland disposal site shall be at least 50 feet from sensitive areas such as storm drains, open ditches, or water bodies, including wetlands.

### ***Design and Installation Specifications***

#### **Implementation**

The following steps will help reduce stormwater pollution from concrete wastes:

- Perform washout of concrete trucks at an approved off-site location or in designated concrete washout areas only.
- Do not wash out concrete trucks onto the ground, or into storm drains, open ditches, streets, or streams.
- Do not allow excess concrete to be dumped on-site, except in designated concrete washout areas.
- Concrete washout areas may be prefabricated concrete washout containers, or self-installed structures (above-grade or below-grade).
- Prefabricated containers are most resistant to damage and protect against spills and leaks. Companies may offer delivery service and provide regular maintenance and disposal of solid and liquid waste.
- If self-installed concrete washout areas are used, below-grade structures are preferred over above-grade structures because they are less prone to spills and leaks.
- Self-installed above-grade structures should only be used if excavation is not practical.

### **Education**

- Discuss the concrete management techniques described in this BMP with the ready-mix concrete supplier before any deliveries are made.
- Educate employees and subcontractors on the concrete waste management techniques described in this BMP.
- Arrange for contractor's superintendent or Certified Erosion and Sediment Control Lead (CESCL) to oversee and enforce concrete waste management procedures.
- A sign should be installed adjacent to each temporary concrete washout facility to inform concrete equipment operators to utilize the proper facilities.

### **Contracts**

Incorporate requirements for concrete waste management into concrete supplier and subcontractor agreements.

### **Location and Placement**

- Locate washout area at least 50 feet from sensitive areas such as storm drains, open ditches, or water bodies, including wetlands.
- Allow convenient access for concrete trucks, preferably near the area where the concrete is being poured.
- If trucks need to leave a paved area to access washout, prevent track-out with a pad of rock or quarry spalls (see [BMP C105](#)). These areas should be far enough away from other construction traffic to reduce the likelihood of accidental damage and spills.
- The number of facilities you install should depend on the expected demand for storage capacity.
- On large sites with extensive concrete work, washouts should be placed in multiple locations for ease of use by concrete truck drivers.

### **On-site Temporary Concrete Washout Facility, Transit Truck Washout Procedures:**

- Temporary concrete washout facilities shall be located a minimum of 50 ft from sensitive areas including storm drain inlets, open drainage facilities, and watercourses. See [Figures 4.1.7](#) and [4.1.8](#).
- Concrete washout facilities shall be constructed and maintained in sufficient quantity and size to contain all liquid and concrete waste generated by washout operations.
- Washout of concrete trucks shall be performed in designated areas only.

- Concrete washout from concrete pumper bins can be washed into concrete pumper trucks and discharged into designated washout area or properly disposed of off-site.
- Once concrete wastes are washed into the designated area and allowed to harden, the concrete should be broken up, removed, and disposed of per applicable solid waste regulations. Dispose of hardened concrete on a regular basis.
- Temporary Above-Grade Concrete Washout Facility
  - Temporary concrete washout facility (type above grade) should be constructed as shown on the details below, with a recommended minimum length and minimum width of 10 ft, but with sufficient quantity and volume to contain all liquid and concrete waste generated by washout operations.
  - Plastic lining material should be a minimum of 10 mil polyethylene sheeting and should be free of holes, tears, or other defects that compromise the impermeability of the material.
- Temporary Below-Grade Concrete Washout Facility
  - Temporary concrete washout facilities (type below grade) should be constructed as shown on the details below, with a recommended minimum length and minimum width of 10 ft. The quantity and volume should be sufficient to contain all liquid and concrete waste generated by washout operations.
  - Lath and flagging should be commercial type.
  - Plastic lining material shall be a minimum of 10 mil polyethylene sheeting and should be free of holes, tears, or other defects that compromise the impermeability of the material.
  - Liner seams shall be installed in accordance with manufacturers' recommendations.
  - Soil base shall be prepared free of rocks or other debris that may cause tears or holes in the plastic lining material.

***Maintenance Standards***

**Inspection and Maintenance**

- Inspect and verify that concrete washout BMPs are in place prior to the commencement of concrete work.
- During periods of concrete work, inspect daily to verify continued performance.
  - Check overall condition and performance.
  - Check remaining capacity (% full).
  - If using self-installed washout facilities, verify plastic liners are intact and sidewalls are not damaged.

- If using prefabricated containers, check for leaks.
- Washout facilities shall be maintained to provide adequate holding capacity with a minimum freeboard of 12 inches.
- Washout facilities must be cleaned, or new facilities must be constructed and ready for use once the washout is 75% full.
- If the washout is nearing capacity, vacuum and dispose of the waste material in an approved manner.
  - Do not discharge liquid or slurry to waterways, storm drains or directly onto ground.
  - Do not use sanitary sewer without local approval.
  - Place a secure, non-collapsing, non-water collecting cover over the concrete washout facility prior to predicted wet weather to prevent accumulation and overflow of precipitation.
  - Remove and dispose of hardened concrete and return the structure to a functional condition. Concrete may be reused on-site or hauled away for disposal or recycling.
- When you remove materials from the self-installed concrete washout, build a new structure; or, if the previous structure is still intact, inspect for signs of weakening or damage, and make any necessary repairs. Re-line the structure with new plastic after each cleaning.

#### **Removal of Temporary Concrete Washout Facilities**

- When temporary concrete washout facilities are no longer required for the work, the hardened concrete, slurries and liquids shall be removed and properly disposed of.
- Materials used to construct temporary concrete washout facilities shall be removed from the site of the work and disposed of or recycled.
- Holes, depressions or other ground disturbance caused by the removal of the temporary concrete washout facilities shall be backfilled, repaired, and stabilized to prevent erosion.

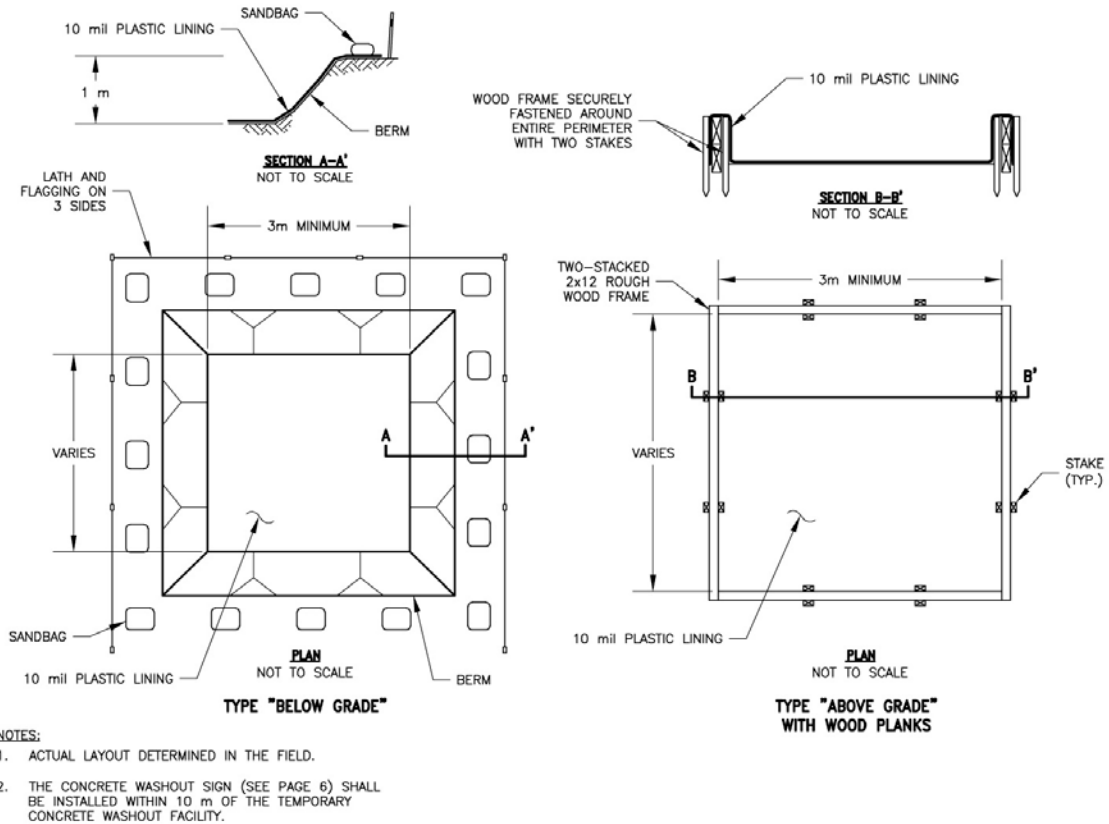

**Figure 4.1.7a – Concrete Washout Area**

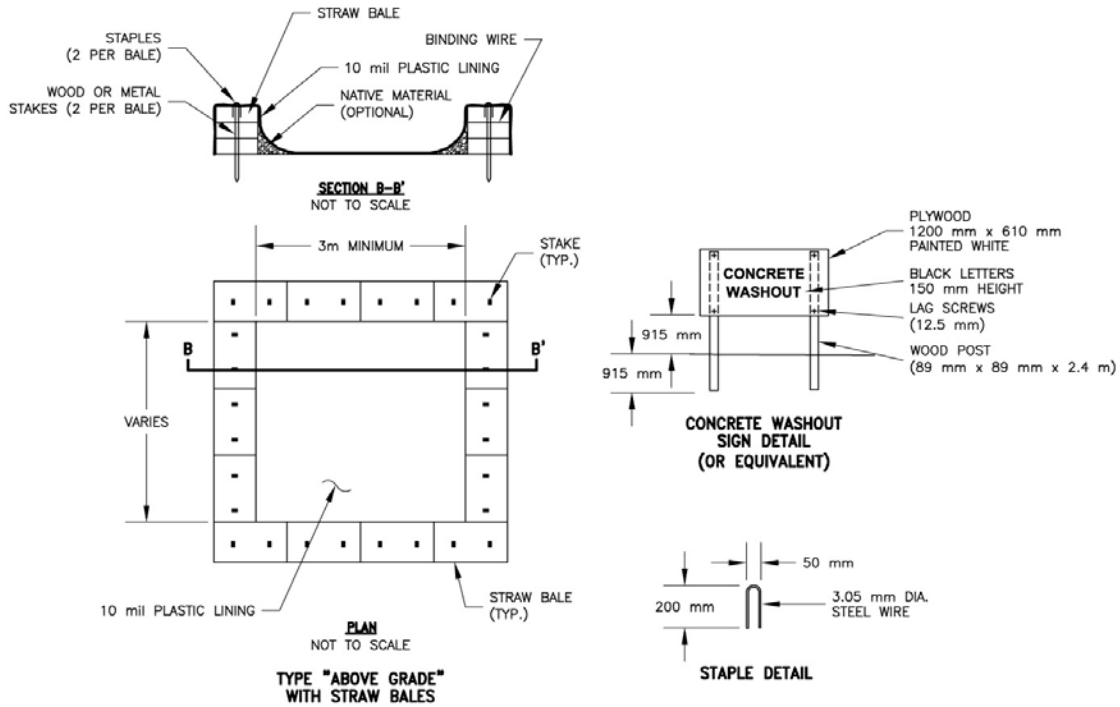

**NOTES:**

1. ACTUAL LAYOUT DETERMINED IN THE FIELD.
2. THE CONCRETE WASHOUT SIGN (SEE FIG. 4-15) SHALL BE INSTALLED WITHIN 10 m OF THE TEMPORARY CONCRETE WASHOUT FACILITY.

CALTRANS/FIG4-14.DWG SAC 8-14-02

**Figure 4.1.7b – Concrete Washout Area**

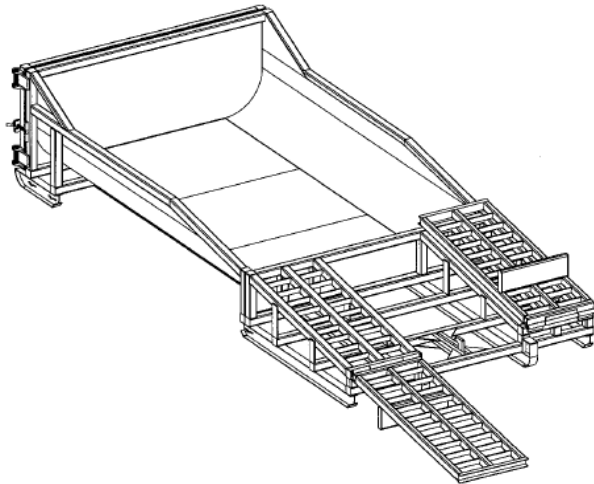

**Figure 4.1.8 – Prefabricated Concrete Washout Container w/Ramp**

## **BMP C160: Certified Erosion and Sediment Control Lead**

### ***Purpose***

The project proponent designates at least one person as the responsible representative in charge of erosion and sediment control (ESC), and water quality protection. The designated person shall be the Certified Erosion and Sediment Control Lead (CESCL) who is responsible for ensuring compliance with all local, state, and federal erosion and sediment control and water quality requirements.

### ***Conditions of Use***

A CESCL shall be made available on projects one acre or larger that discharge stormwater to surface waters of the state. Sites less than one acre may have a person without CESCL certification conduct inspections; sampling is not required on sites that disturb less than an acre.

- The CESCL shall:
  - Have a current certificate proving attendance in an erosion and sediment control training course that meets the minimum ESC training and certification requirements established by Ecology (see details below).

Ecology will maintain a list of ESC training and certification providers at:

<http://www.ecy.wa.gov/programs/wq/stormwater/cescl.html>

### **OR**

- Be a Certified Professional in Erosion and Sediment Control (CPESC); for additional information go to: [www.cpesc.net](http://www.cpesc.net)

### ***Specifications***

- Certification shall remain valid for three years.
- The CESCL shall have authority to act on behalf of the contractor or developer and shall be available, or on-call, 24 hours per day throughout the period of construction.
- The Construction SWPPP shall include the name, telephone number, fax number, and address of the designated CESCL.
- A CESCL may provide inspection and compliance services for multiple construction projects in the same geographic region.

Duties and responsibilities of the CESCL shall include, but are not limited to the following:

- Maintaining permit file on site at all times which includes the Construction SWPPP and any associated permits and plans.
- Directing BMP installation, inspection, maintenance, modification, and removal.



- Updating all project drawings and the Construction SWPPP with changes made.
- Completing any sampling requirements including reporting results using WebDMR.
- Keeping daily logs, and inspection reports. Inspection reports should include:
  - Inspection date/time.
  - Weather information; general conditions during inspection and approximate amount of precipitation since the last inspection.
  - A summary or list of all BMPs implemented, including observations of all erosion/sediment control structures or practices. The following shall be noted:
    1. Locations of BMPs inspected.
    2. Locations of BMPs that need maintenance.
    3. Locations of BMPs that failed to operate as designed or intended.
    4. Locations of where additional or different BMPs are required.
    - Visual monitoring results, including a description of discharged stormwater. The presence of suspended sediment, turbid water, discoloration, and oil sheen shall be noted, as applicable.
    - Any water quality monitoring performed during inspection.
    - General comments and notes, including a brief description of any BMP repairs, maintenance or installations made as a result of the inspection.
- Facilitate, participate in, and take corrective actions resulting from inspections performed by outside agencies or the owner.

## **BMP C162: Scheduling**

***Purpose*** Sequencing a construction project reduces the amount and duration of soil exposed to erosion by wind, rain, runoff, and vehicle tracking.

***Conditions of Use*** The construction sequence schedule is an orderly listing of all major land-disturbing activities together with the necessary erosion and sedimentation control measures planned for the project. This type of schedule guides the contractor on work to be done before other work is started so that serious erosion and sedimentation problems can be avoided.

Following a specified work schedule that coordinates the timing of land-disturbing activities and the installation of control measures is perhaps the most cost-effective way of controlling erosion during construction. The removal of surface ground cover leaves a site vulnerable to accelerated

erosion. Construction procedures that limit land clearing provide timely installation of erosion and sedimentation controls, and restore protective cover quickly can significantly reduce the erosion potential of a site.

***Design  
Considerations***

- Minimize construction during rainy periods.
- Schedule projects to disturb only small portions of the site at any one time. Complete grading as soon as possible. Immediately stabilize the disturbed portion before grading the next portion. Practice staged seeding in order to revegetate cut and fill slopes as the work progresses.

## 4.2 Runoff Conveyance and Treatment BMPs

This section contains the standards and specifications for Runoff Conveyance and Treatment BMPs. [Table 4.2.1](#), below, shows the relationship of the BMPs in Section 4.2 to the Construction Stormwater Pollution Prevention Plan (SWPPP) [Elements](#) described in [Section 3.3.3](#).

**Table 4.2.1 Runoff Conveyance and Treatment BMPs by SWPPP Element**

BMP or Element Name	Element #3 Control Flow Rates	Element #4 Install Sediment Controls	Element #6 Protect Slopes	Element #7 Protect Drain Inlets	Element #8 Stabilize Channels and Outlets	Element #9 Control Pollutants	Element #10 Control De-Watering	Element #13 Protect Low Impact Development
BMP C200: Interceptor Dike and Swale			✓					✓
BMP C201: Grass-Lined Channels			✓					✓
BMP C202: Channel Lining					✓			
BMP C203: Water Bars	✓		✓				✓	
BMP C204: Pipe Slope Drains			✓					
BMP C205: Subsurface Drains			✓					
BMP C206: Level Spreader			✓				✓	
BMP C207: Check Dams	✓		✓		✓			✓
BMP C208: Triangular Silt Dike (TSD) (Geotextile Encased Check Dam)			✓					✓
BMP C209: Outlet Protection	✓				✓			
BMP C220: Storm Drain Inlet Protection				✓				
BMP C231: Brush Barrier		✓						✓
BMP C232: Gravel Filter Berm		✓						
BMP C233: Silt Fence		✓						✓
BMP C234: Vegetated Strip		✓						✓
BMP C235: Wattles	✓	✓						
BMP C236: Vegetated Filtration							✓	
BMP C240: Sediment Trap	✓	✓						
BMP C241: Temporary Sediment Pond	✓	✓						

<b>BMP C250:</b> Construction Stormwater Chemical Treatment		✓				✓		
<b>BMP C251:</b> Construction Stormwater Filtration		✓				✓		
<b>BMP C252:</b> High pH Neutralization Using CO <sub>2</sub>						✓		
<b>BMP C253:</b> pH Control for High pH Water						✓		

## **BMP C200: Interceptor Dike and Swale**

### ***Purpose***

Provide a ridge of compacted soil, or a ridge with an upslope swale, at the top or base of a disturbed slope or along the perimeter of a disturbed construction area to convey stormwater. Use the dike and/or swale to intercept the runoff from unprotected areas and direct it to areas where erosion can be controlled. This can prevent storm runoff from entering the work area or sediment-laden runoff from leaving the construction site.

### ***Conditions of Use***

Where the runoff from an exposed site or disturbed slope must be conveyed to an erosion control facility which can safely convey the stormwater.

- Locate upslope of a construction site to prevent runoff from entering disturbed area.
- When placed horizontally across a disturbed slope, it reduces the amount and velocity of runoff flowing down the slope.
- Locate downslope to collect runoff from a disturbed area and direct water to a sediment basin.

### ***Design and Installation Specifications***

- Dike and/or swale and channel must be stabilized with temporary or permanent vegetation or other channel protection during construction.
- Channel requires a positive grade for drainage; steeper grades require channel protection and check dams.
- Review construction for areas where overtopping may occur.
- Can be used at top of new fill before vegetation is established.
- May be used as a permanent diversion channel to carry the runoff.
- Sub-basin tributary area should be one acre or less.
- Design capacity for the peak volumetric flow rate calculated using a 10-minute time step from a 10-year, 24-hour storm, assuming a Type 1A rainfall distribution, for temporary facilities. Alternatively, use 1.6 times the 10-year, 1-hour flow indicated by an approved continuous runoff model. For facilities that will also serve on a permanent basis, consult the local government's drainage requirements.

**Interceptor dikes** shall meet the following criteria:

Top Width	2 feet minimum.
Height	1.5 feet minimum on berm.
Side Slope	2H:1V or flatter.
Grade	Depends on topography, however, dike system minimum is 0.5%, and maximum is 1%.
Compaction	Minimum of 90 percent ASTM D698 standard proctor.

Horizontal Spacing of Interceptor Dikes:

Average Slope	Slope Percent	Flowpath Length
20H:1V or less	3-5%	300 feet
(10 to 20)H:1V	5-10%	200 feet
(4 to 10)H:1V	10-25%	100 feet
(2 to 4)H:1V	25-50%	50 feet

Stabilization depends on velocity and reach

Slopes <5%	Seed and mulch applied within 5 days of dike construction (see <a href="#">BMP C121, Mulching</a> ).
Slopes 5 - 40%	Dependent on runoff velocities and dike materials. Stabilization should be done immediately using either sod or riprap or other measures to avoid erosion.

- The upslope side of the dike shall provide positive drainage to the dike outlet. No erosion shall occur at the outlet. Provide energy dissipation measures as necessary. Sediment-laden runoff must be released through a sediment trapping facility.
- Minimize construction traffic over temporary dikes. Use temporary cross culverts for channel crossing.

**Interceptor swales** shall meet the following criteria:

Bottom Width	2 feet minimum; the cross-section bottom shall be level.
Depth	1-foot minimum.
Side Slope	2H:1V or flatter.
Grade	Maximum 5 percent, with positive drainage to a suitable outlet (such as a sediment pond).
Stabilization	Seed as per <a href="#">BMP C120, Temporary and Permanent Seeding</a> , or <a href="#">BMP C202, Channel Lining</a> , 12 inches thick riprap pressed into the bank and extending at least 8 inches vertical from the bottom.

- Inspect diversion dikes and interceptor swales once a week and after every rainfall. Immediately remove sediment from the flow area.

- Damage caused by construction traffic or other activity must be repaired before the end of each working day.

Check outlets and make timely repairs as needed to avoid gully formation. When the area below the temporary diversion dike is permanently stabilized, remove the dike and fill and stabilize the channel to blend with the natural surface.

## **BMP C201: Grass-Lined Channels**

**Purpose** To provide a channel with a vegetative lining for conveyance of runoff. See [Figure 4.2.1](#) for typical grass-lined channels.

**Conditions of Use** This practice applies to construction sites where concentrated runoff needs to be contained to prevent erosion or flooding.

- When a vegetative lining can provide sufficient stability for the channel cross section and at lower velocities of water (normally dependent on grade). This means that the channel slopes are generally less than 5 percent and space is available for a relatively large cross section.
- Typical uses include roadside ditches, channels at property boundaries, outlets for diversions, and other channels and drainage ditches in low areas.
- Channels that will be vegetated should be installed before major earthwork and hydroseeded with a bonded fiber matrix (BFM). The vegetation should be well established (i.e., 75 percent cover) before water is allowed to flow in the ditch. With channels that will have high flows, erosion control blankets should be installed over the hydroseed. If vegetation cannot be established from seed before water is allowed in the ditch, sod should be installed in the bottom of the ditch in lieu of hydromulch and blankets.

### ***Design and Installation Specifications***

Locate the channel where it can conform to the topography and other features such as roads.

- Locate them to use natural drainage systems to the greatest extent possible.
- Avoid sharp changes in alignment or bends and changes in grade.
- Do not reshape the landscape to fit the drainage channel.
- The maximum design velocity shall be based on soil conditions, type of vegetation, and method of revegetation, but at no times shall velocity exceed 5 feet/second. The channel shall not be overtopped by the peak volumetric flow rate calculated using a 10-minute time step from a 10-year, 24-hour storm, assuming a Type 1A rainfall distribution. Alternatively, use 1.6 times the 10-year, 1-hour flow indicated by an approved continuous runoff model to determine a flow rate which the channel must contain.

- Where the grass-lined channel will also function as a permanent stormwater conveyance facility, consult the drainage conveyance requirements of the local government with jurisdiction.
- An established grass or vegetated lining is required before the channel can be used to convey stormwater, unless stabilized with nets or blankets.
- If design velocity of a channel to be vegetated by seeding exceeds 2 ft/sec, a temporary channel liner is required. Geotextile or special mulch protection such as fiberglass roving or straw and netting provides stability until the vegetation is fully established. See [Figure 4.2.2](#).
- Check dams shall be removed when the grass has matured sufficiently to protect the ditch or swale unless the slope of the swale is greater than 4 percent. The area beneath the check dams shall be seeded and mulched immediately after dam removal.
- If vegetation is established by sodding, the permissible velocity for established vegetation may be used and no temporary liner is needed.
- Do not subject grass-lined channel to sedimentation from disturbed areas. Use sediment-trapping BMPs upstream of the channel.
- V-shaped grass channels generally apply where the quantity of water is small, such as in short reaches along roadsides. The V-shaped cross section is least desirable because it is difficult to stabilize the bottom where velocities may be high.
- Trapezoidal grass channels are used where runoff volumes are large and slope is low so that velocities are nonerosive to vegetated linings. (Note: it is difficult to construct small parabolic shaped channels.)
- Subsurface drainage, or riprap channel bottoms, may be necessary on sites that are subject to prolonged wet conditions due to long duration flows or a high water table.
- Provide outlet protection at culvert ends and at channel intersections.
- Grass channels, at a minimum, should carry peak runoff for temporary construction drainage facilities from the 10-year, 24-hour storm without eroding. Where flood hazard exists, increase the capacity according to the potential damage.
- Grassed channel side slopes generally are constructed 3H:1V or flatter to aid in the establishment of vegetation and for maintenance.
- Construct channels a minimum of 0.2 foot larger around the periphery to allow for soil bulking during seedbed preparations and sod buildup.

***Maintenance  
Standards***

During the establishment period, check grass-lined channels after every rainfall.

- After grass is established, periodically check the channel; check it after every heavy rainfall event. Immediately make repairs.
- It is particularly important to check the channel outlet and all road crossings for bank stability and evidence of piping or scour holes.
- Remove all significant sediment accumulations to maintain the designed carrying capacity. Keep the grass in a healthy, vigorous condition at all times, since it is the primary erosion protection for the channel.



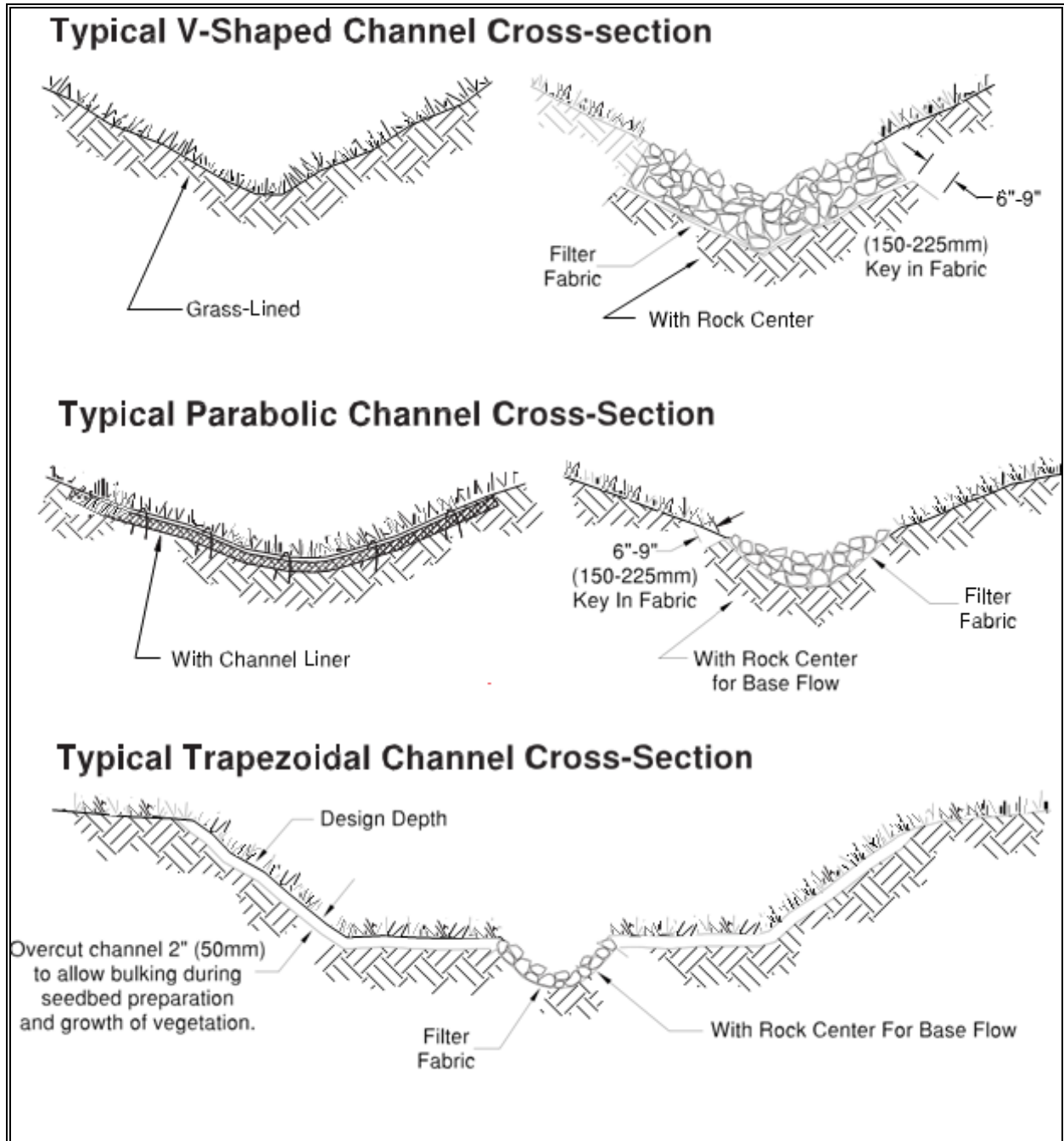
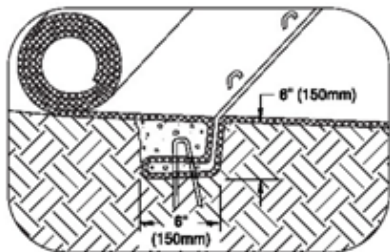
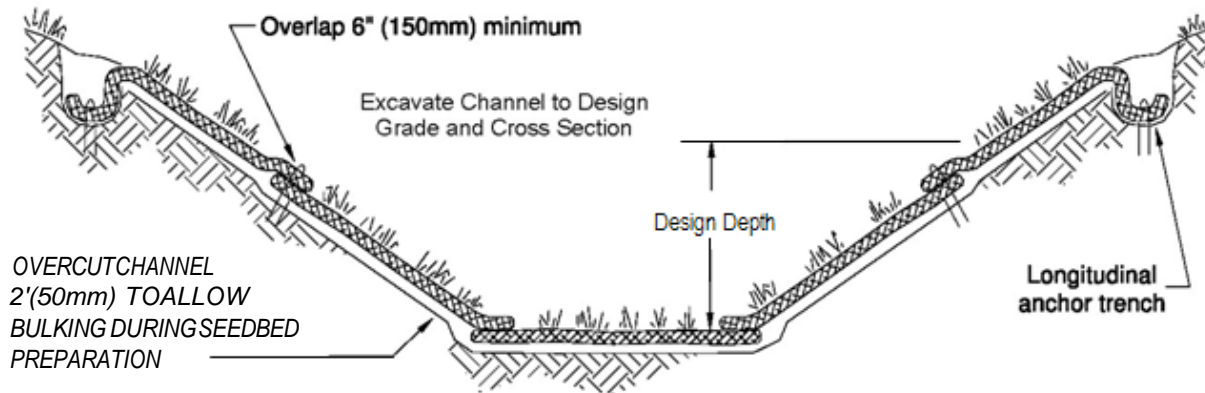
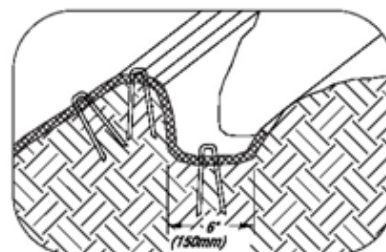

Figure 4.2.1 – Typical Grass-Lined Channels



Intermittent Check Slot

TYPICAL INSTALLATION WITH EROSION CONTROL BLANKETS OR TURF REINFORCEMENT MATS



Longitudinal Anchor Trench

Shingle-lap spliced ends or begin new roll in an intermittent check slot

Prepare soil and apply seed before installing blankets, mats or other temporary channel liner system

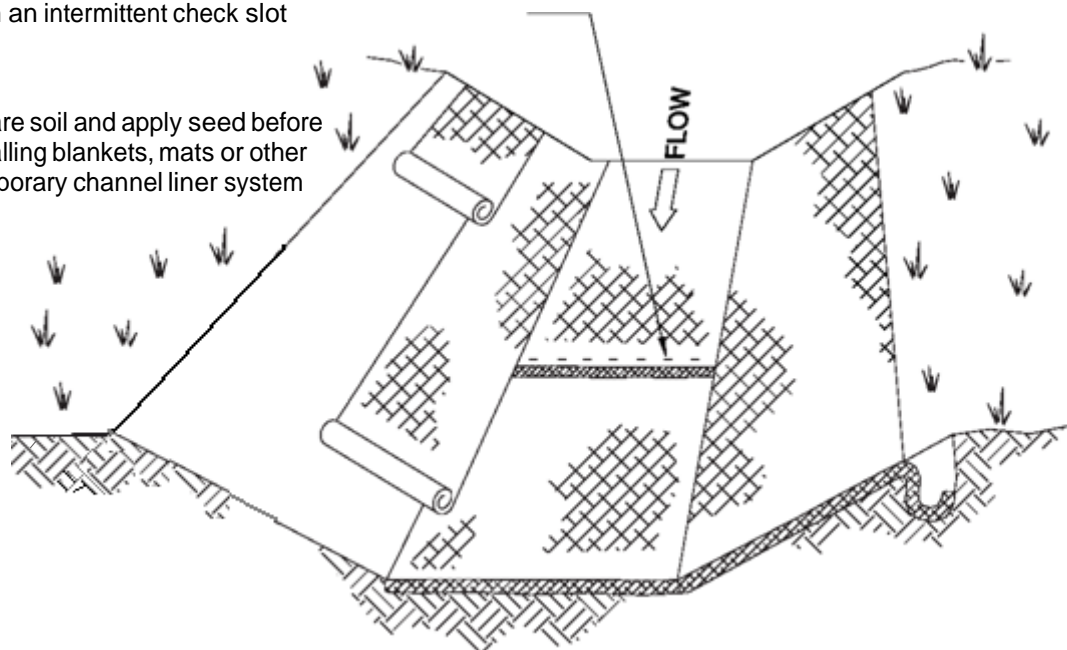

NOTES:

- 1 Design velocities exceeding 2 ft/sec (0.5m/sec) require temporary blankets, mats or similar liners to protect seed and soil until vegetation becomes established.
- 2 Grass-lined channels with design velocities exceeding 6 ft/sec (2m/sec) should include turf reinforcement mats.

**Figure 4.2.2 – Temporary Channel Liners**

## **BMP C202: Channel Lining**

<b><i>Purpose</i></b>	To protect channels by providing a channel liner using either blankets or riprap.
<b><i>Conditions of Use</i></b>	<p>When natural soils or vegetated stabilized soils in a channel are not adequate to prevent channel erosion.</p> <ul style="list-style-type: none"><li>• When a permanent ditch or pipe system is to be installed and a temporary measure is needed.</li><li>• In almost all cases, synthetic and organic coconut blankets are more effective than riprap for protecting channels from erosion. Blankets can be used with and without vegetation. Blanketed channels can be designed to handle any expected flow and longevity requirement. Some synthetic blankets have a predicted life span of 50 years or more, even in sunlight.</li><li>• Other reasons why blankets are better than rock include the availability of blankets over rock. In many areas of the state, rock is not easily obtainable or is very expensive to haul to a site. Blankets can be delivered anywhere. Rock requires the use of dump trucks to haul and heavy equipment to place. Blankets usually only require laborers with hand tools, and sometimes a backhoe.</li><li>• The Federal Highway Administration recommends not using flexible liners whenever the slope exceeds 10 percent or the shear stress exceeds 8 lbs/ft<sup>2</sup>.</li></ul>
<b><i>Design and Installation Specifications</i></b>	<p>See <a href="#">BMP C122</a> for information on blankets.</p> <p>Since riprap is used where erosion potential is high, construction must be sequenced so that the riprap is put in place with the minimum possible delay.</p> <ul style="list-style-type: none"><li>• Disturbance of areas where riprap is to be placed should be undertaken only when final preparation and placement of the riprap can follow immediately behind the initial disturbance. Where riprap is used for outlet protection, the riprap should be placed before or in conjunction with the construction of the pipe or channel so that it is in place when the pipe or channel begins to operate.</li><li>• The designer, after determining the riprap size that will be stable under the flow conditions, shall consider that size to be a minimum size and then, based on riprap gradations actually available in the area, select the size or sizes that equal or exceed the minimum size. The possibility of drainage structure damage by children shall be considered in selecting a riprap size, especially if there is nearby water or a gully in which to toss the stones.</li><li>• Stone for riprap shall consist of field stone or quarry stone of approximately rectangular shape. The stone shall be hard and angular</li></ul>

and of such quality that it will not disintegrate on exposure to water or weathering and it shall be suitable in all respects for the purpose intended.

- A lining of engineering filter fabric (geotextile) shall be placed between the riprap and the underlying soil surface to prevent soil movement into or through the riprap. The geotextile should be keyed in at the top of the bank.
- Filter fabric shall not be used on slopes greater than 1-1/2H:1V as slippage may occur. It should be used in conjunction with a layer of coarse aggregate (granular filter blanket) when the riprap to be placed is 12 inches and larger.

**BMP C203: Water Bars**

***Purpose***

A small ditch or ridge of material is constructed diagonally across a road or right-of-way to divert stormwater runoff from the road surface, wheel tracks, or a shallow road ditch. See [Figure 4.2.3](#).

***Conditions of use***

Clearing right-of-way and construction of access for power lines, pipelines, and other similar installations often require long narrow right-of-ways over sloping terrain. Disturbance and compaction promotes gully formation in these cleared strips by increasing the volume and velocity of runoff. Gully formation may be especially severe in tire tracks and ruts. To prevent gullying, runoff can often be diverted across the width of the right-of-way to undisturbed areas by using small pre-designed diversions.

- Give special consideration to each individual outlet area, as well as to the cumulative effect of added diversions. Use gravel to stabilize the diversion where significant vehicular traffic is anticipated.

***Design and Installation Specifications***

Height: 8-inch minimum measured from the channel bottom to the ridge top.

- Side slope of channel: 2H:1V maximum; 3H:1V or flatter when vehicles will cross.
- Base width of ridge: 6-inch minimum.
- Locate them to use natural drainage systems and to discharge into well vegetated stable areas.
- Guideline for Spacing:

Slope %	Spacing (ft)
< 5	125
5 - 10	100
10 - 20	75
20 - 35	50
> 35	Use rock lined ditch

- Grade of water bar and angle: Select angle that results in ditch slope less than 2 percent.
- Install as soon as the clearing and grading is complete. Reconstruct when construction is complete on a section when utilities are being installed.
- Compact the ridge when installed.
- Stabilize, seed, and mulch the portions that are not subject to traffic. Gravel the areas crossed by vehicles.

***Maintenance Standards***

Periodically inspect right-of-way diversions for wear and after every heavy rainfall for erosion damage.

- Immediately remove sediment from the flow area and repair the dike.
- Check outlet areas and make timely repairs as needed.
- When permanent road drainage is established and the area above the temporary right-of-way diversion is permanently stabilized, remove the dikes and fill the channel to blend with the natural ground, and appropriately stabilize the disturbed area.

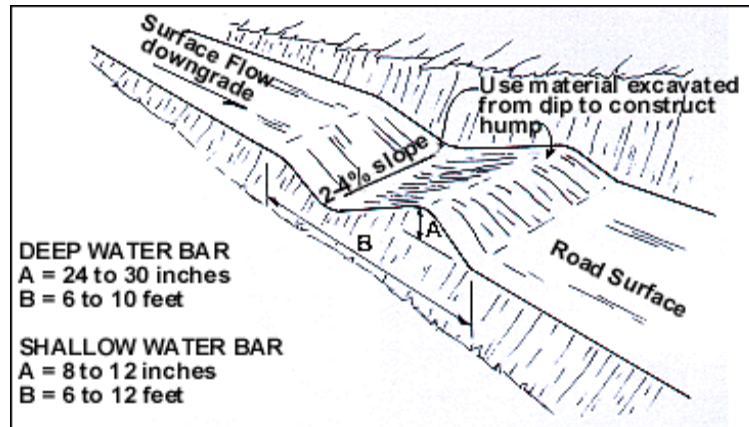

**Figure 4.2.3 – Water Bar**

## **BMP C204: Pipe Slope Drains**

- Purpose*** To use a pipe to convey stormwater anytime water needs to be diverted away from or over bare soil to prevent gullies, channel erosion, and saturation of slide-prone soils.
- Conditions of Use*** Pipe slope drains should be used when a temporary or permanent stormwater conveyance is needed to move the water down a steep slope to avoid erosion ([Figure 4.2.4](#)).
- On highway projects, pipe slope drains should be used at bridge ends to collect runoff and pipe it to the base of the fill slopes along bridge approaches. These can be designed into a project and included as bid items. Another use on road projects is to collect runoff from pavement and pipe it away from side slopes. These are useful because there is generally a time lag between having the first lift of asphalt installed and the curbs, gutters, and permanent drainage installed. Used in conjunction with sand bags, or other temporary diversion devices, these will prevent massive amounts of sediment from leaving a project.
- Water can be collected, channeled with sand bags, Triangular Silt Dikes, berms, or other material, and piped to temporary sediment ponds.
- Pipe slope drains can be:
- Connected to new catch basins and used temporarily until all permanent piping is installed;
  - Used to drain water collected from aquifers exposed on cut slopes and take it to the base of the slope;
  - Used to collect clean runoff from plastic sheeting and direct it away from exposed soil;
  - Installed in conjunction with silt fence to drain collected water to a controlled area;
  - Used to divert small seasonal streams away from construction. They have been used successfully on culvert replacement and extension jobs. Large flex pipe can be used on larger streams during culvert removal, repair, or replacement; and,
  - Connected to existing down spouts and roof drains and used to divert water away from work areas during building renovation, demolition, and construction projects.
- There are now several commercially available collectors that are attached to the pipe inlet and help prevent erosion at the inlet.

***Design and  
Installation  
Specifications***

Size the pipe to convey the flow. The capacity for temporary drains shall be sufficient to handle the peak volumetric flow rate calculated using a 10-minute time step from a 10-year, 24-hour storm event, assuming a Type 1A rainfall distribution. Alternatively, use 1.6 times the 10-year, 1-hour flow indicated by an approved continuous runoff model.

Consult local drainage requirements for sizing permanent pipe slope drains.

- Use care in clearing vegetated slopes for installation.
- Re-establish cover immediately on areas disturbed by installation.
- Use temporary drains on new cut or fill slopes.
- Use diversion dikes or swales to collect water at the top of the slope.
- Ensure that the entrance area is stable and large enough to direct flow into the pipe.
- Piping of water through the berm at the entrance area is a common failure mode.
- The entrance shall consist of a standard flared end section for culverts 12 inches and larger with a minimum 6-inch metal toe plate to prevent runoff from undercutting the pipe inlet. The slope of the entrance shall be at least 3 percent. Sand bags may also be used at pipe entrances as a temporary measure.
- The soil around and under the pipe and entrance section shall be thoroughly compacted to prevent undercutting.
- The flared inlet section shall be securely connected to the slope drain and have watertight connecting bands.
- Slope drain sections shall be securely fastened together, fused or have gasketed watertight fittings, and shall be securely anchored into the soil.
- Thrust blocks should be installed anytime 90 degree bends are utilized. Depending on size of pipe and flow, these can be constructed with sand bags, straw bales staked in place, “t” posts and wire, or ecology blocks.
- Pipe needs to be secured along its full length to prevent movement. This can be done with steel “t” posts and wire. A post is installed on each side of the pipe and the pipe is wired to them. This should be done every 10-20 feet of pipe length or so, depending on the size of the pipe and quantity of water to divert.
- Interceptor dikes shall be used to direct runoff into a slope drain. The height of the dike shall be at least 1 foot higher at all points than the top of the inlet pipe.
- The area below the outlet must be stabilized with a riprap apron (see [BMP C209](#) Outlet Protection, for the appropriate outlet material).

- If the pipe slope drain is conveying sediment-laden water, direct all flows into the sediment trapping facility.
- Materials specifications for any permanent piped system shall be set by the local government.

***Maintenance Standards***

Check inlet and outlet points regularly, especially after storms.

The inlet should be free of undercutting, and no water should be going around the point of entry. If there are problems, the headwall should be reinforced with compacted earth or sand bags.

- The outlet point should be free of erosion and installed with appropriate outlet protection.
- For permanent installations, inspect pipe periodically for vandalism and physical distress such as slides and wind-throw.
- Normally the pipe slope is so steep that clogging is not a problem with smooth wall pipe, however, debris may become lodged in the pipe.

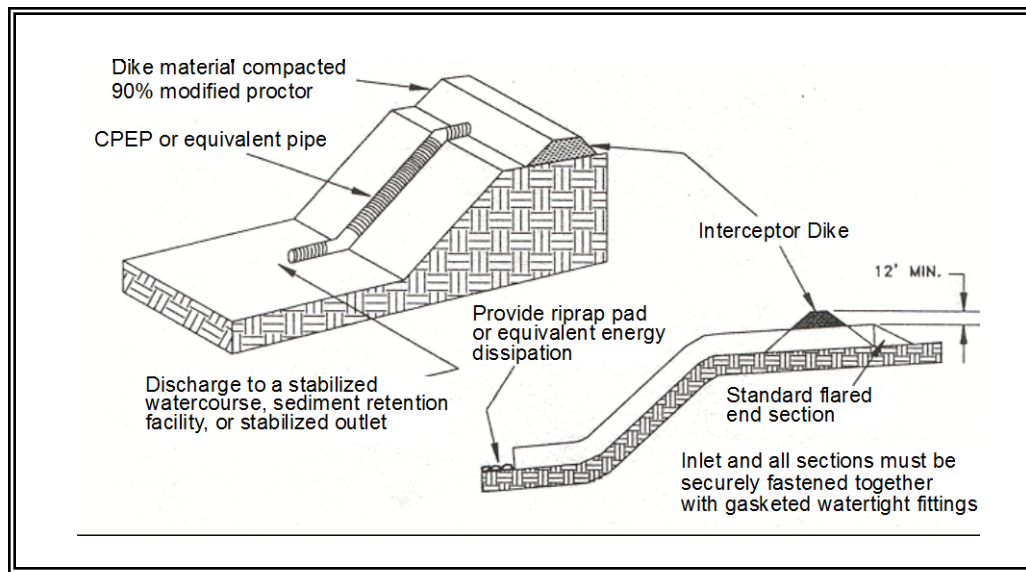

**Figure 4.2.4 – Pipe Slope Drain**



## **BMP C205: Subsurface Drains**

<i><b>Purpose</b></i>	To intercept, collect, and convey ground water to a satisfactory outlet, using a perforated pipe or conduit below the ground surface. Subsurface drains are also known as “french drains.” The perforated pipe provides a dewatering mechanism to drain excessively wet soils, provide a stable base for construction, improve stability of structures with shallow foundations, or to reduce hydrostatic pressure to improve slope stability.
<i><b>Conditions of Use</b></i>	Use when excessive water must be removed from the soil. The soil permeability, depth to water table and impervious layers are all factors which may govern the use of subsurface drains.
<i><b>Design and Installation Specifications</b></i>	<p><b>Relief drains</b> are used either to lower the water table in large, relatively flat areas, improve the growth of vegetation, or to remove surface water.</p> <p>Relief drains are installed along a slope and drain in the direction of the slope.</p> <p>They can be installed in a grid pattern, a herringbone pattern, or a random pattern.</p> <ul style="list-style-type: none"><li>• <b>Interceptor drains</b> are used to remove excess ground water from a slope, stabilize steep slopes, and lower the water table immediately below a slope to prevent the soil from becoming saturated.</li></ul> <p>Interceptor drains are installed perpendicular to a slope and drain to the side of the slope.</p> <p>They usually consist of a single pipe or series of single pipes instead of a patterned layout.</p> <ul style="list-style-type: none"><li>• <b>Depth and spacing of interceptor drains</b> --The depth of an interceptor drain is determined primarily by the depth to which the water table is to be lowered or the depth to a confining layer. For practical reasons, the maximum depth is usually limited to 6 feet, with a minimum cover of 2 feet to protect the conduit.</li><li>• The soil should have depth and sufficient permeability to permit installation of an effective drainage system at a depth of 2 to 6 feet.</li><li>• An adequate outlet for the drainage system must be available either by gravity or by pumping.</li><li>• The quantity and quality of discharge needs to be accounted for in the receiving stream (additional detention may be required).</li><li>• This standard does not apply to subsurface drains for building foundations or deep excavations.</li><li>• The capacity of an interceptor drain is determined by calculating the maximum rate of ground water flow to be intercepted. Therefore, it is</li></ul>

good practice to make complete subsurface investigations, including hydraulic conductivity of the soil, before designing a subsurface drainage system.

- **Size of drain**--Size subsurface drains to carry the required capacity without pressure flow. Minimum diameter for a subsurface drain is 4 inches.
- The minimum velocity required to prevent silting is 1.4 ft./sec. The line shall be graded to achieve this velocity at a minimum. The maximum allowable velocity using a sand-gravel filter or envelope is 9 ft/sec.
- Filter material and fabric shall be used around all drains for proper bedding and filtration of fine materials. Envelopes and filters should surround the drain to a minimum of 3-inch thickness.
- The outlet of the subsurface drain shall empty into a sediment pond through a catch basin. If free of sediment, it can then empty into a receiving channel, swale, or stable vegetated area adequately protected from erosion and undermining.
- The trench shall be constructed on a continuous grade with no reverse grades or low spots.
- Soft or yielding soils under the drain shall be stabilized with gravel or other suitable material.
- Backfilling shall be done immediately after placement of the pipe. No sections of pipe shall remain uncovered overnight or during a rainstorm. Backfill material shall be placed in the trench in such a manner that the drain pipe is not displaced or damaged.
- Do not install permanent drains near trees to avoid the tree roots that tend to clog the line. Use solid pipe with watertight connections where it is necessary to pass a subsurface drainage system through a stand of trees.
- **Outlet**--Ensure that the outlet of a drain empties into a channel or other watercourse above the normal water level.
- Secure an animal guard to the outlet end of the pipe to keep out rodents.
- Use outlet pipe of corrugated metal, cast iron, or heavy-duty plastic without perforations and at least 10 feet long. Do not use an envelope or filter material around the outlet pipe, and bury at least two-thirds of the pipe length.
- When outlet velocities exceed those allowable for the receiving stream, outlet protection must be provided.

***Maintenance Standards***

Subsurface drains shall be checked periodically to ensure that they are free-flowing and not clogged with sediment or roots.

- The outlet shall be kept clean and free of debris.
- Surface inlets shall be kept open and free of sediment and other debris.
- Trees located too close to a subsurface drain often clog the system with their roots. If a drain becomes clogged, relocate the drain or remove the trees as a last resort. Drain placement should be planned to minimize this problem.
- Where drains are crossed by heavy vehicles, the line shall be checked to ensure that it is not crushed.

**BMP C206: Level Spreader**

***Purpose***

To provide a temporary outlet for dikes and diversions consisting of an excavated depression constructed at zero grade across a slope. To convert concentrated runoff to sheet flow and release it onto areas stabilized by existing vegetation or an engineered filter strip.

***Conditions of Use***

Used when a concentrated flow of water needs to be dispersed over a large area with existing stable vegetation.

- Items to consider are:
  1. What is the risk of erosion or damage if the flow may become concentrated?
  2. Is an easement required if discharged to adjoining property?
  3. Most of the flow should be as ground water and not as surface flow.
  4. Is there an unstable area downstream that cannot accept additional ground water?
- Use only where the slopes are gentle, the water volume is relatively low, and the soil will adsorb most of the low flow events.

***Design and Installation Specifications***

Use above undisturbed areas that are stabilized by existing vegetation.

If the level spreader has any low points, flow will concentrate, create channels and may cause erosion.

- Discharge area below the outlet must be uniform with a slope flatter than 5H:1V.
- Outlet to be constructed level in a stable, undisturbed soil profile (not on fill).
- The runoff shall not re-concentrate after release unless intercepted by another downstream measure.

- The grade of the channel for the last 20 feet of the dike or interceptor entering the level spreader shall be less than or equal to 1 percent. The grade of the level spreader shall be 0 percent to ensure uniform spreading of storm runoff.
- A 6-inch high gravel berm placed across the level lip shall consist of washed crushed rock, 2- to 4-inch or 3/4-inch to 1½-inch size.
- The spreader length shall be determined by estimating the peak flow expected from the 10-year, 24-hour design storm. The length of the spreader shall be a minimum of 15 feet for 0.1 cfs and shall increase by 10 feet for each 0.1 cfs thereafter to a maximum of 0.5 cfs per spreader. Use multiple spreaders for higher flows.
- The width of the spreader should be at least 6 feet.
- The depth of the spreader as measured from the lip should be at least 6 inches and it should be uniform across the entire length.
- Level spreaders shall be setback from the property line unless there is an easement for flow.
- Level spreaders, when installed every so often in grassy swales, keep the flows from concentrating. Materials that can be used include sand bags, lumber, logs, concrete, and pipe. To function properly, the material needs to be installed level and on contour. [Figures 4.2.5](#) and [4.2.6](#) provide a cross-section and a detail of a level spreader. A capped perforated pipe could also be used as a spreader.

**Maintenance Standards**

The spreader should be inspected after every runoff event to ensure that it is functioning correctly.

- The contractor should avoid the placement of any material on the structure and should prevent construction traffic from crossing over the structure.
- If the spreader is damaged by construction traffic, it shall be immediately repaired.

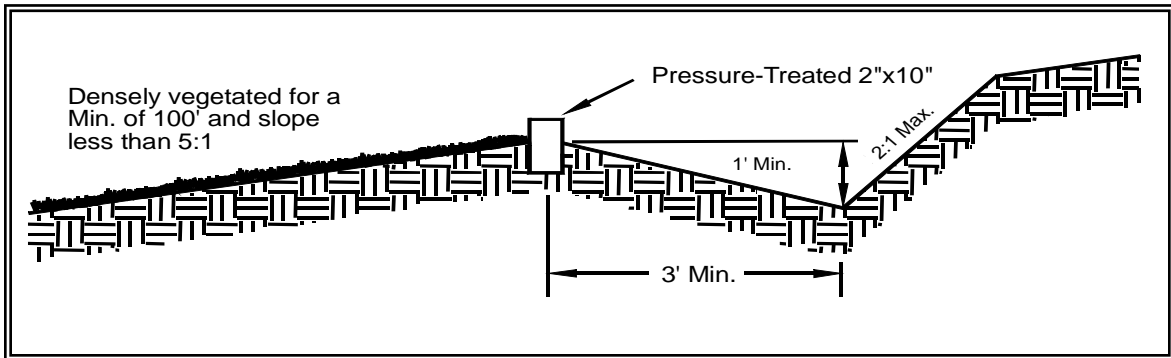

**Figure 4.2.5 – Cross Section of Level Spreader**

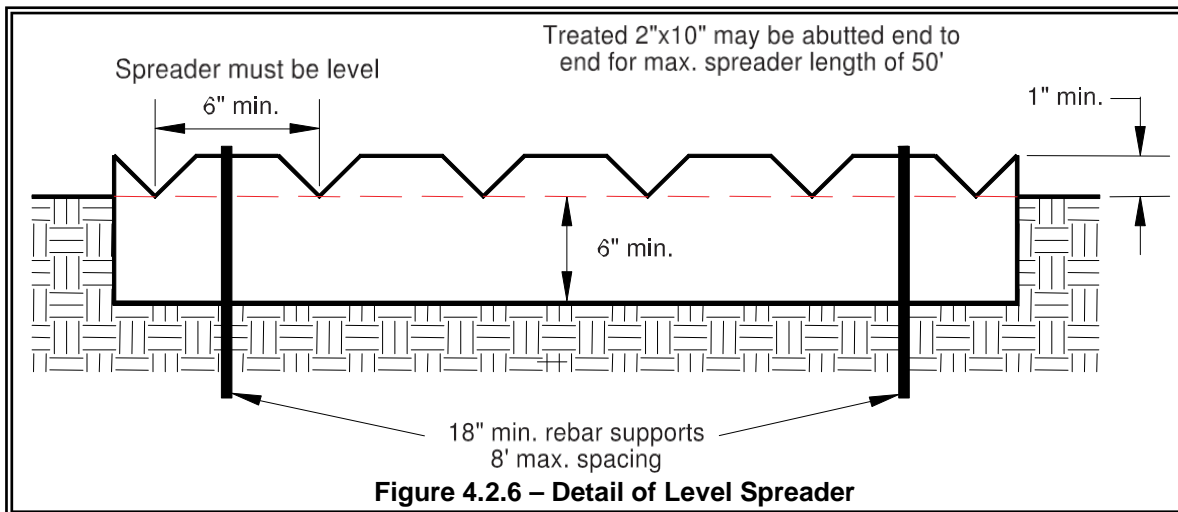

## BMP C207: Check Dams

### *Purpose*

Construction of small dams across a swale or ditch reduces the velocity of concentrated flow and dissipates energy at the check dam.

### *Conditions of Use*

Where temporary channels or permanent channels are not yet vegetated, channel lining is infeasible, and/or velocity checks are required.

- Check dams may not be placed in streams unless approved by the State Department of Fish and Wildlife. Check dams may not be placed in wetlands without approval from a permitting agency.
- Do not place check dams below the expected backwater from any salmonid bearing water between October 1 and May 31 to ensure that there is no loss of high flow refuge habitat for overwintering juvenile salmonids and emergent salmonid fry.
- Construct rock check dams from appropriately sized rock. The rock used must be large enough to stay in place given the expected design flow through the channel. The rock must be placed by hand or by mechanical means (no dumping of rock to form dam) to achieve complete coverage of the ditch or swale and to ensure that the center of the dam is lower than the edges.
- Check dams may also be constructed of either rock or pea-gravel filled bags. Numerous new products are also available for this purpose. They tend to be re-usable, quick and easy to install, effective, and cost efficient.
- Place check dams perpendicular to the flow of water.
- The dam should form a triangle when viewed from the side. This prevents undercutting as water flows over the face of the dam rather than falling directly onto the ditch bottom.

- Before installing check dams impound and bypass upstream water flow away from the work area. Options for bypassing include pumps, siphons, or temporary channels.
- Check dams in association with sumps work more effectively at slowing flow and retaining sediment than just a check dam alone. A deep sump should be provided immediately upstream of the check dam.
- In some cases, if carefully located and designed, check dams can remain as permanent installations with very minor regrading. They may be left as either spillways, in which case accumulated sediment would be graded and seeded, or as check dams to prevent further sediment from leaving the site.
- The maximum spacing between the dams shall be such that the toe of the upstream dam is at the same elevation as the top of the downstream dam.
- Keep the maximum height at 2 feet at the center of the dam.
- Keep the center of the check dam at least 12 inches lower than the outer edges at natural ground elevation.
- Keep the side slopes of the check dam at 2H:1V or flatter.
- Key the stone into the ditch banks and extend it beyond the abutments a minimum of 18 inches to avoid washouts from overflow around the dam.
- Use filter fabric foundation under a rock or sand bag check dam. If a blanket ditch liner is used, filter fabric is not necessary. A piece of organic or synthetic blanket cut to fit will also work for this purpose.
- In the case of grass-lined ditches and swales, all check dams and accumulated sediment shall be removed when the grass has matured sufficiently to protect the ditch or swale - unless the slope of the swale is greater than 4 percent. The area beneath the check dams shall be seeded and mulched immediately after dam removal.
- Ensure that channel appurtenances, such as culvert entrances below check dams, are not subject to damage or blockage from displaced stones. [Figure 4.2.7](#) depicts a typical rock check dam.

### ***Maintenance Standards***

Check dams shall be monitored for performance and sediment accumulation during and after each runoff producing rainfall. Sediment shall be removed when it reaches one half the sump depth.

- Anticipate submergence and deposition above the check dam and erosion from high flows around the edges of the dam.
- If significant erosion occurs between dams, install a protective riprap liner in that portion of the channel.

***Approved as  
Equivalent***

Ecology has approved products as able to meet the requirements of [BMP C207](#). The products did not pass through the Technology Assessment Protocol – Ecology (TAPE) process. Local jurisdictions may choose not to accept this product approved as equivalent, or may require additional testing prior to consideration for local use. The products are available for review on Ecology’s website at <http://www.ecy.wa.gov/programs/wq/stormwater/newtech/equivalent.html>

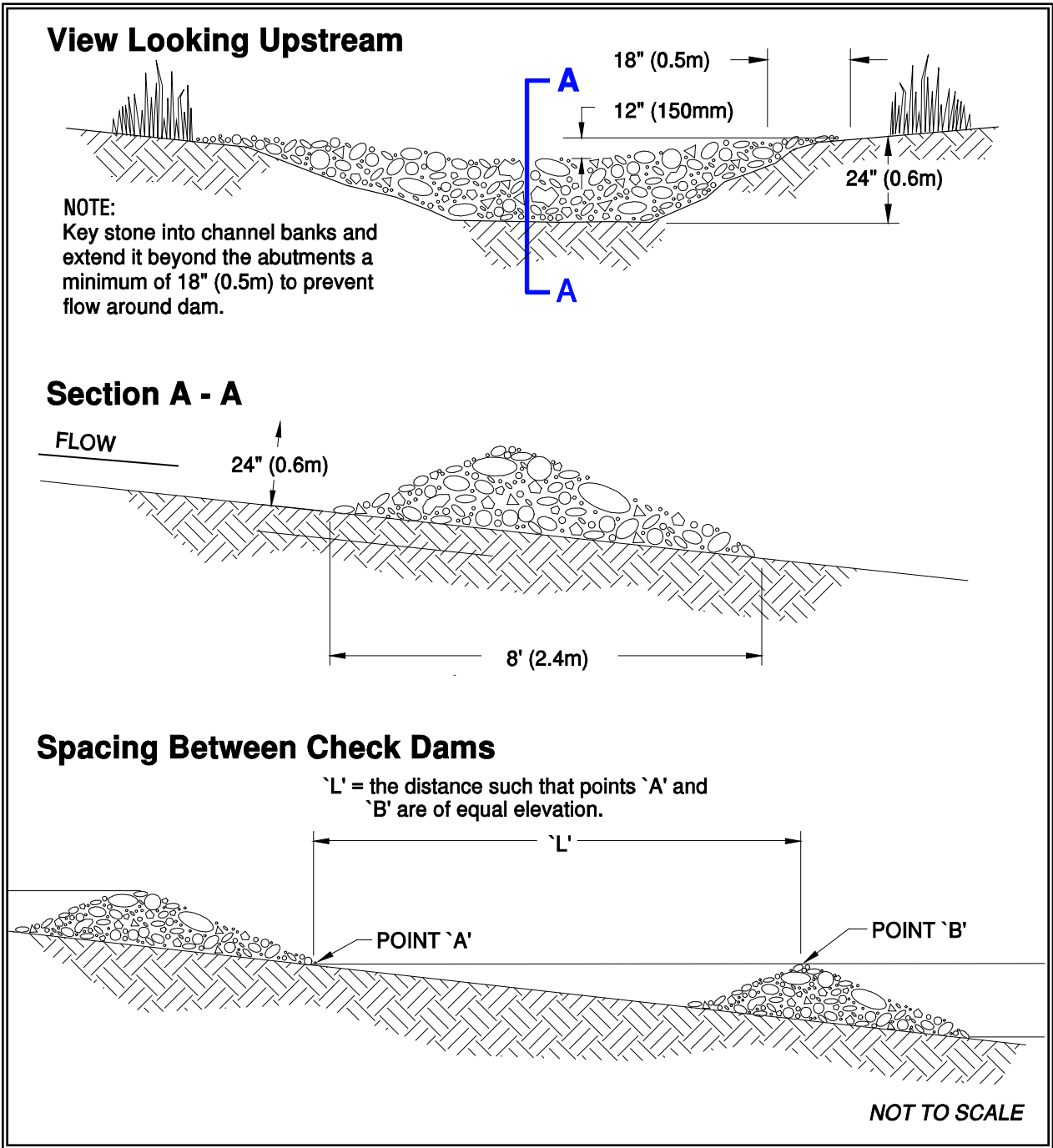

Figure 4.2.7 – Rock Check Dam



## **BMP C208: Triangular Silt Dike (TSD) (Geotextile-Encased Check Dam)**

**Purpose** Triangular silt dikes may be used as check dams, for perimeter protection, for temporary soil stockpile protection, for drop inlet protection, or as a temporary interceptor dike.

**Conditions of use**

- May be used on soil or pavement with adhesive or staples.
- TSDs have been used to build temporary:
  1. sediment ponds;
  2. diversion ditches;
  3. concrete wash out facilities;
  4. curbing;
  5. water bars;
  6. level spreaders; and,
  7. berms.

**Design and Installation Specifications**

Made of urethane foam sewn into a woven geosynthetic fabric.

It is triangular, 10 inches to 14 inches high in the center, with a 20-inch to 28-inch base. A 2-foot apron extends beyond both sides of the triangle along its standard section of 7 feet. A sleeve at one end allows attachment of additional sections as needed.

- Install with ends curved up to prevent water from flowing around the ends.
- The fabric flaps and check dam units are attached to the ground with wire staples. Wire staples should be No. 11 gauge wire and should be 200 mm to 300 mm in length.
- When multiple units are installed, the sleeve of fabric at the end of the unit shall overlap the abutting unit and be stapled.
- Check dams should be located and installed as soon as construction will allow.
- Check dams should be placed perpendicular to the flow of water.
- When used as check dams, the leading edge must be secured with rocks, sandbags, or a small key slot and staples.
- In the case of grass-lined ditches and swales, check dams and accumulated sediment shall be removed when the grass has matured sufficiently to protect the ditch or swale unless the slope of the swale is greater than 4 percent. The area beneath the check dams shall be seeded and mulched immediately after dam removal.

**Maintenance**

- Triangular silt dams shall be inspected for performance and sediment

## ***Standards***

accumulation during and after each runoff producing rainfall. Sediment shall be removed when it reaches one half the height of the dam.

- Anticipate submergence and deposition above the triangular silt dam and erosion from high flows around the edges of the dam. Immediately repair any damage or any undercutting of the dam.

## **BMP C209: Outlet Protection**

### ***Purpose***

Outlet protection prevents scour at conveyance outlets and minimizes the potential for downstream erosion by reducing the velocity of concentrated stormwater flows.

### ***Conditions of use***

Outlet protection is required at the outlets of all ponds, pipes, ditches, or other conveyances, and where runoff is conveyed to a natural or manmade drainage feature such as a stream, wetland, lake, or ditch.

### ***Design and Installation Specifications***

The receiving channel at the outlet of a culvert shall be protected from erosion by rock lining a minimum of 6 feet downstream and extending up the channel sides a minimum of 1-foot above the maximum tailwater elevation or 1-foot above the crown, whichever is higher. For large pipes (more than 18 inches in diameter), the outlet protection lining of the channel is lengthened to four times the diameter of the culvert.

- Standard wingwalls, and tapered outlets and paved channels should also be considered when appropriate for permanent culvert outlet protection. (See WSDOT Hydraulic Manual, available through WSDOT Engineering Publications).
- Organic or synthetic erosion blankets, with or without vegetation, are usually more effective than rock, cheaper, and easier to install. Materials can be chosen using manufacturer product specifications. ASTM test results are available for most products and the designer can choose the correct material for the expected flow.
- With low flows, vegetation (including sod) can be effective.
- The following guidelines shall be used for riprap outlet protection:
  1. If the discharge velocity at the outlet is less than 5 fps (pipe slope less than 1 percent), use 2-inch to 8-inch riprap. Minimum thickness is 1-foot.
  2. For 5 to 10 fps discharge velocity at the outlet (pipe slope less than 3 percent), use 24-inch to 48-inch riprap. Minimum thickness is 2 feet.
  3. For outlets at the base of steep slope pipes (pipe slope greater than 10 percent), an engineered energy dissipater shall be used.
- Filter fabric or erosion control blankets should always be used under riprap to prevent scour and channel erosion.

- New pipe outfalls can provide an opportunity for low-cost fish habitat improvements. For example, an alcove of low-velocity water can be created by constructing the pipe outfall and associated energy dissipater back from the stream edge and digging a channel, over-widened to the upstream side, from the outfall. Overwintering juvenile and migrating adult salmonids may use the alcove as shelter during high flows. Bank stabilization, bioengineering, and habitat features may be required for disturbed areas. This work may require a HPA. See Volume V for more information on outfall system design.

***Maintenance Standards***

- Inspect and repair as needed.
- Add rock as needed to maintain the intended function.
- Clean energy dissipater if sediment builds up.

**BMP C220: Storm Drain Inlet Protection**

***Purpose***

Storm drain inlet protection prevents coarse sediment from entering drainage systems prior to permanent stabilization of the disturbed area.

***Conditions of Use***

Use storm drain inlet protection at inlets that are operational before permanent stabilization of the disturbed drainage area. Provide protection for all storm drain inlets downslope and within 500 feet of a disturbed or construction area, unless conveying runoff entering catch basins to a sediment pond or trap.

Also consider inlet protection for lawn and yard drains on new home construction. These small and numerous drains coupled with lack of gutters in new home construction can add significant amounts of sediment into the roof drain system. If possible delay installing lawn and yard drains until just before landscaping or cap these drains to prevent sediment from entering the system until completion of landscaping. Provide 18-inches of sod around each finished lawn and yard drain.

[Table 4.2.2](#) lists several options for inlet protection. All of the methods for storm drain inlet protection tend to plug and require a high frequency of maintenance. Limit drainage areas to one acre or less. Possibly provide emergency overflows with additional end-of-pipe treatment where stormwater ponding would cause a hazard.

<b>Table 4.2.2 Storm Drain Inlet Protection</b>			
<b>Type of Inlet Protection</b>	<b>Emergency Overflow</b>	<b>Applicable for Paved/ Earthen Surfaces</b>	<b>Conditions of Use</b>
<b>Drop Inlet Protection</b>			
Excavated drop inlet protection	Yes, temporary flooding will occur	Earthen	Applicable for heavy flows. Easy to maintain. Large area Requirement: 30' X 30'/acre
Block and gravel drop inlet protection	Yes	Paved or Earthen	Applicable for heavy concentrated flows. Will not pond.
Gravel and wire drop inlet protection	No		Applicable for heavy concentrated flows. Will pond. Can withstand traffic.
Catch basin filters	Yes	Paved or Earthen	Frequent maintenance required.
<b>Curb Inlet Protection</b>			
Curb inlet protection with a wooden weir	Small capacity overflow	Paved	Used for sturdy, more compact installation.
Block and gravel curb inlet protection	Yes	Paved	Sturdy, but limited filtration.
<b>Culvert Inlet Protection</b>			
Culvert inlet sediment trap			18 month expected life.

***Design and Installation Specifications***

*Excavated Drop Inlet Protection* - An excavated impoundment around the storm drain. Sediment settles out of the stormwater prior to entering the storm drain.

- Provide a depth of 1-2 ft as measured from the crest of the inlet structure.
- Slope sides of excavation no steeper than 2H:1V.
- Minimum volume of excavation 35 cubic yards.
- Shape basin to fit site with longest dimension oriented toward the longest inflow area.
- Install provisions for draining to prevent standing water problems.
- Clear the area of all debris.
- Grade the approach to the inlet uniformly.
- Drill weep holes into the side of the inlet.
- Protect weep holes with screen wire and washed aggregate.
- Seal weep holes when removing structure and stabilizing area.

- Build a temporary dike, if necessary, to the down slope side of the structure to prevent bypass flow.

*Block and Gravel Filter* - A barrier formed around the storm drain inlet with standard concrete blocks and gravel. See [Figure 4.2.8](#).

- Provide a height of 1 to 2 feet above inlet.
- Recess the first row 2-inches into the ground for stability.
- Support subsequent courses by placing a 2x4 through the block opening.
- Do not use mortar.
- Lay some blocks in the bottom row on their side for dewatering the pool.
- Place hardware cloth or comparable wire mesh with ½-inch openings over all block openings.
- Place gravel just below the top of blocks on slopes of 2H:1V or flatter.
- An alternative design is a gravel donut.
- Provide an inlet slope of 3H:1V.
- Provide an outlet slope of 2H:1V.
- Provide a 1-foot wide level stone area between the structure and the inlet.
- Use inlet slope stones 3 inches in diameter or larger.
- Use gravel ½- to ¾-inch at a minimum thickness of 1-foot for the outlet slope.

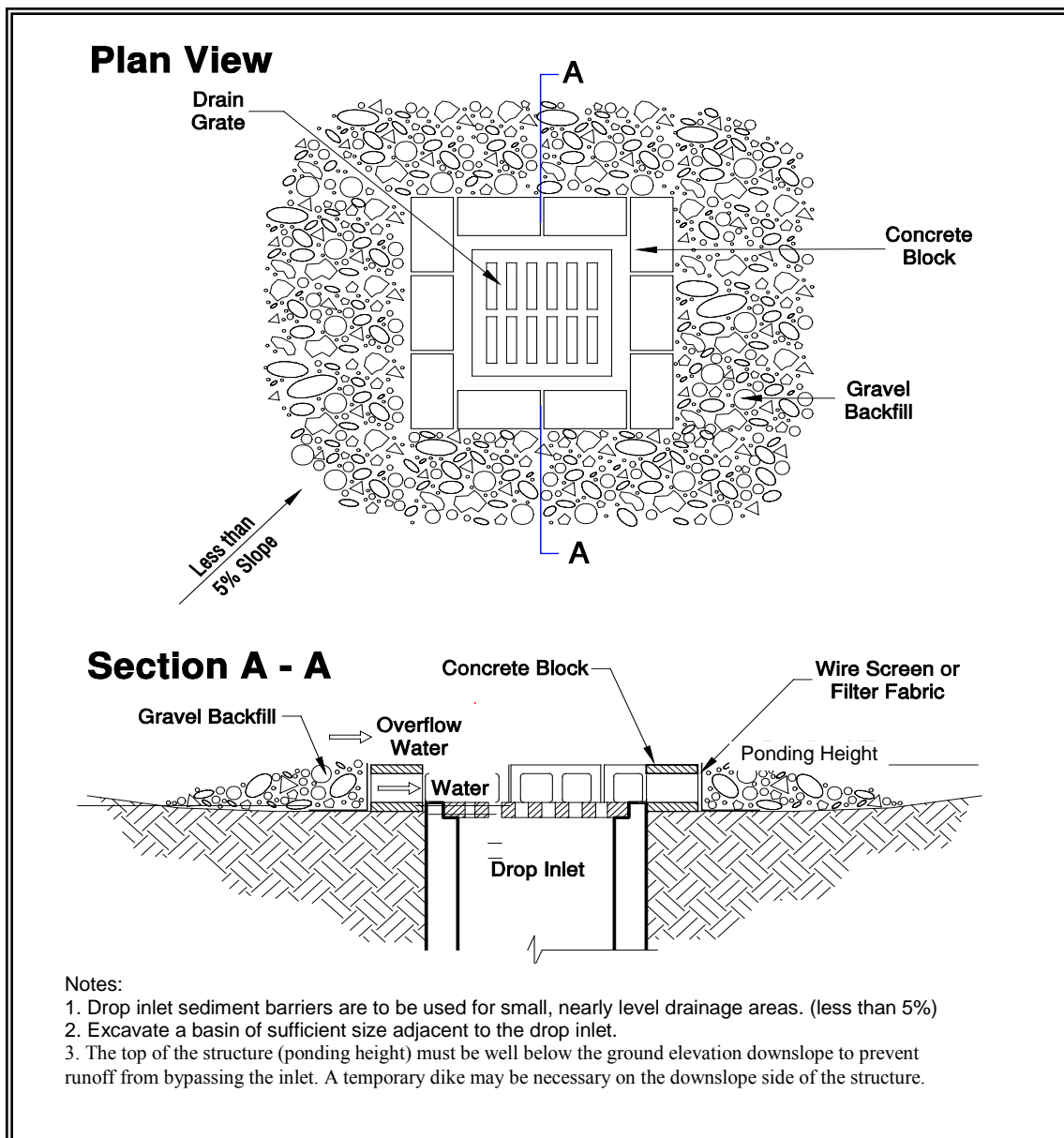

**Figure 4.2.8 – Block and Gravel Filter**

*Gravel and Wire Mesh Filter* - A gravel barrier placed over the top of the inlet. This structure does not provide an overflow.

- Use a hardware cloth or comparable wire mesh with ½-inch openings.
- Use coarse aggregate.
- Provide a height 1-foot or more, 18-inches wider than inlet on all sides.
- Place wire mesh over the drop inlet so that the wire extends a minimum of 1-foot beyond each side of the inlet structure.
- Overlap the strips if more than one strip of mesh is necessary.

- Place coarse aggregate over the wire mesh.
- Provide at least a 12-inch depth of gravel over the entire inlet opening and extend at least 18-inches on all sides.

*Catchbasin Filters* – Use inserts designed by manufacturers for construction sites. The limited sediment storage capacity increases the amount of inspection and maintenance required, which may be daily for heavy sediment loads. To reduce maintenance requirements combine a catchbasin filter with another type of inlet protection. This type of inlet protection provides flow bypass without overflow and therefore may be a better method for inlets located along active rights-of-way.

- Provides 5 cubic feet of storage.
- Requires dewatering provisions.
- Provides a high-flow bypass that will not clog under normal use at a construction site.
- Insert the catchbasin filter in the catchbasin just below the grating.

*Curb Inlet Protection with Wooden Weir* – Barrier formed around a curb inlet with a wooden frame and gravel.

- Use wire mesh with ½-inch openings.
- Use extra strength filter cloth.
- Construct a frame.
- Attach the wire and filter fabric to the frame.
- Pile coarse washed aggregate against wire/fabric.
- Place weight on frame anchors.

*Block and Gravel Curb Inlet Protection* – Barrier formed around a curb inlet with concrete blocks and gravel. See [Figure 4.2.9](#).

- Use wire mesh with ½-inch openings.
- Place two concrete blocks on their sides abutting the curb at either side of the inlet opening. These are spacer blocks.
- Place a 2x4 stud through the outer holes of each spacer block to align the front blocks.
- Place blocks on their sides across the front of the inlet and abutting the spacer blocks.
- Place wire mesh over the outside vertical face.
- Pile coarse aggregate against the wire to the top of the barrier.

*Curb and Gutter Sediment Barrier* – Sandbag or rock berm (riprap and aggregate) 3 feet high and 3 feet wide in a horseshoe shape. See [Figure 4.2.10](#).

***Maintenance Standards***

- Construct a horseshoe shaped berm, faced with coarse aggregate if using riprap, 3 feet high and 3 feet wide, at least 2 feet from the inlet.
- Construct a horseshoe shaped sedimentation trap on the outside of the berm sized to sediment trap standards for protecting a culvert inlet.
- Inspect catch basin filters frequently, especially after storm events. Clean and replace clogged inserts. For systems with clogged stone filters: pull away the stones from the inlet and clean or replace. An alternative approach would be to use the clogged stone as fill and put fresh stone around the inlet.
- Do not wash sediment into storm drains while cleaning. Spread all excavated material evenly over the surrounding land area or stockpile and stabilize as appropriate.

***Approved as Equivalent***

Ecology has approved products as able to meet the requirements of [BMP C220](#). The products did not pass through the Technology Assessment Protocol – Ecology (TAPE) process. Local jurisdictions may choose not to accept this product approved as equivalent, or may require additional testing prior to consideration for local use. The products are available for review on Ecology’s website at <http://www.ecy.wa.gov/programs/wq/stormwater/newtech/equivalent.html>



## Plan View

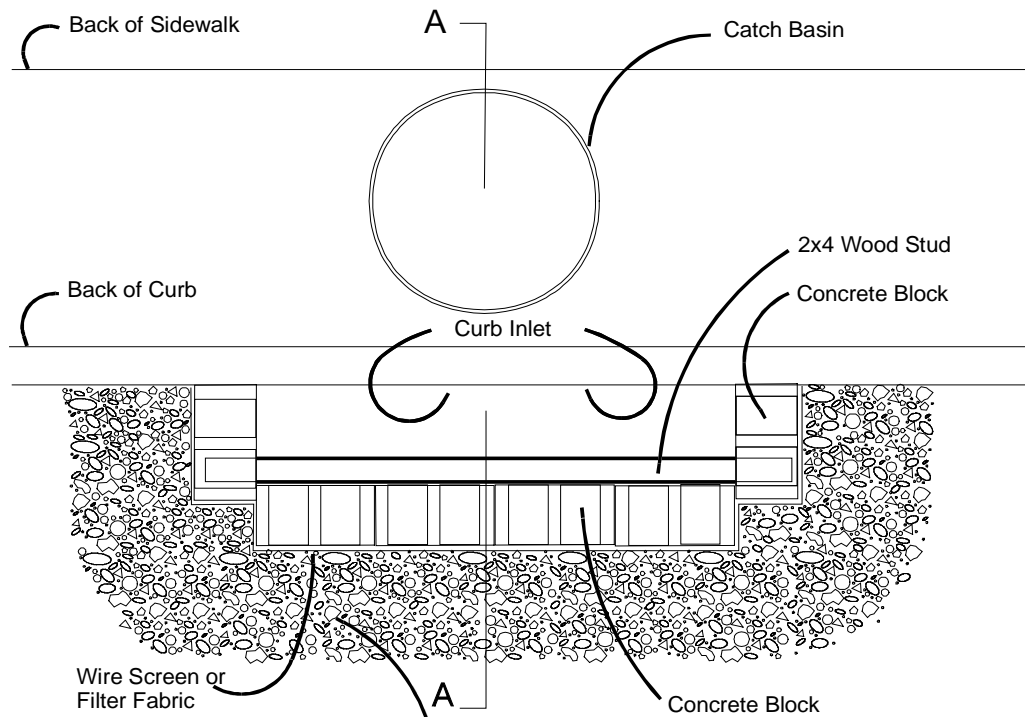

## Section A - A

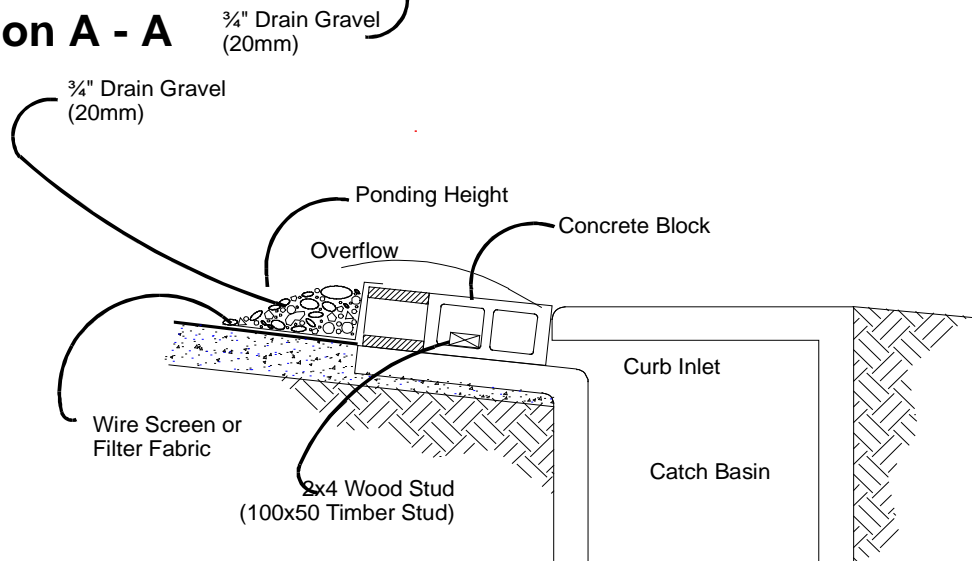

### NOTES:

1. Use block and gravel type sediment barrier when curb inlet is located in gently sloping street segment, where water can pond and allow sediment to separate from runoff.
2. Barrier shall allow for overflow from severe storm event.
3. Inspect barriers and remove sediment after each storm event. Sediment and gravel must be removed from the traveled way immediately.

**Figure 4.2.9 – Block and Gravel Curb Inlet Protection**

## Plan View

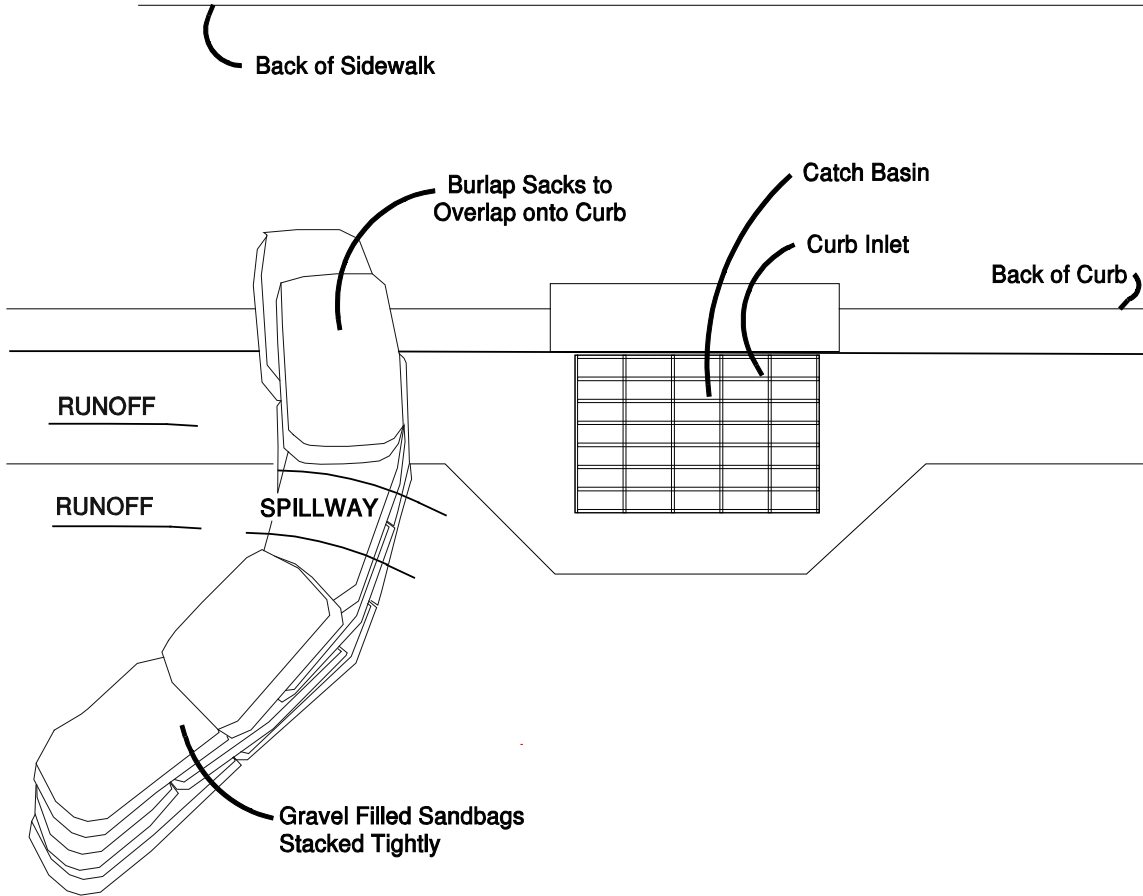

### NOTES:

1. Place curb type sediment barriers on gently sloping street segments, where water can pond and allow sediment to separate from runoff.
2. Sandbags of either burlap or woven 'geotextile' fabric, are filled with gravel, layered and packed tightly.
3. Leave a one sandbag gap in the top row to provide a spillway for overflow.
4. Inspect barriers and remove sediment after each storm event. Sediment and gravel must be removed from the traveled way immediately.

Figure 4.2.10 – Curb and Gutter Barrier

## BMP C231: Brush Barrier

### *Purpose*

The purpose of brush barriers is to reduce the transport of coarse sediment from a construction site by providing a temporary physical barrier to sediment and reducing the runoff velocities of overland flow.

### *Conditions of Use*

- Brush barriers may be used downslope of all disturbed areas of less than one-quarter acre.
- Brush barriers are not intended to treat concentrated flows, nor are they intended to treat substantial amounts of overland flow. Any concentrated flows must be conveyed through the drainage system to a sediment pond. The only circumstance in which overland flow can be treated solely by a brush barrier, rather than by a sediment pond, is when the area draining to the barrier is small.
- Brush barriers should only be installed on contours.

### *Design and Installation Specifications*

- Height 2 feet (minimum) to 5 feet (maximum).
- Width 5 feet at base (minimum) to 15 feet (maximum).
- Filter fabric (geotextile) may be anchored over the brush berm to enhance the filtration ability of the barrier. Ten-ounce burlap is an adequate alternative to filter fabric.
- Chipped site vegetation, composted mulch, or wood-based mulch (hog fuel) can be used to construct brush barriers.
- A 100 percent biodegradable installation can be constructed using 10-ounce burlap held in place by wooden stakes. [Figure 4.2.11](#) depicts a typical brush barrier.

### *Maintenance Standards*

- There shall be no signs of erosion or concentrated runoff under or around the barrier. If concentrated flows are bypassing the barrier, it must be expanded or augmented by toed-in filter fabric.
- The dimensions of the barrier must be maintained.

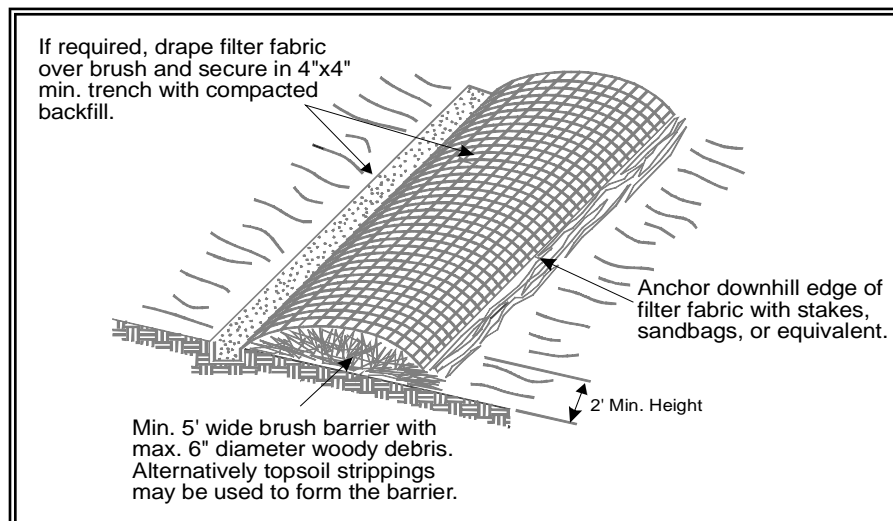

**Figure 4.2.11 – Brush Barrier**

## **BMP C232: Gravel Filter Berm**

<i><b>Purpose</b></i>	A gravel filter berm is constructed on rights-of-way or traffic areas within a construction site to retain sediment by using a filter berm of gravel or crushed rock.
<i><b>Conditions of Use</b></i>	Where a temporary measure is needed to retain sediment from rights-of-way or in traffic areas on construction sites.
<i><b>Design and Installation Specifications</b></i>	<ul style="list-style-type: none"><li>• Berm material shall be <math>\frac{3}{4}</math> to 3 inches in size, washed well-grade gravel or crushed rock with less than 5 percent fines.</li><li>• Spacing of berms:<ul style="list-style-type: none"><li>– Every 300 feet on slopes less than 5 percent</li><li>– Every 200 feet on slopes between 5 percent and 10 percent</li><li>– Every 100 feet on slopes greater than 10 percent</li></ul></li><li>• Berm dimensions:<ul style="list-style-type: none"><li>– 1 foot high with 3H:1V side slopes</li><li>– 8 linear feet per 1 cfs runoff based on the 10-year, 24-hour design storm</li></ul></li></ul>
<i><b>Maintenance Standards</b></i>	<ul style="list-style-type: none"><li>• Regular inspection is required. Sediment shall be removed and filter material replaced as needed.</li></ul>

## **BMP C233: Silt Fence**

<i><b>Purpose</b></i>	Use of a silt fence reduces the transport of coarse sediment from a construction site by providing a temporary physical barrier to sediment and reducing the runoff velocities of overland flow. See <a href="#">Figure 4.2.12</a> for details on silt fence construction.
<i><b>Conditions of Use</b></i>	Silt fence may be used downslope of all disturbed areas. <ul style="list-style-type: none"><li>• Silt fence shall prevent soil carried by runoff water from going beneath, through, or over the top of the silt fence, but shall allow the water to pass through the fence.</li><li>• Silt fence is not intended to treat concentrated flows, nor is it intended to treat substantial amounts of overland flow. Convey any concentrated flows through the drainage system to a sediment pond.</li><li>• Do not construct silt fences in streams or use in V-shaped ditches. Silt fences do not provide an adequate method of silt control for anything deeper than sheet or overland flow.</li></ul>

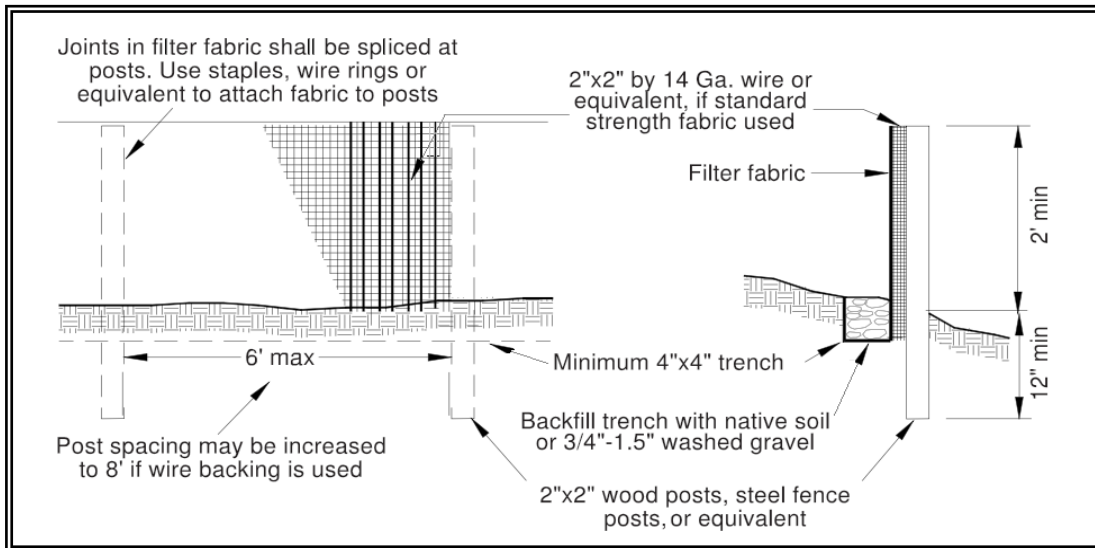

**Figure 4.2.12 – Silt Fence**

***Design and Installation Specifications***

- Use in combination with sediment basins or other BMPs.
- Maximum slope steepness (normal (perpendicular) to fence line) 1H:1V.
- Maximum sheet or overland flow path length to the fence of 100 feet.
- Do not allow flows greater than 0.5 cfs.
- The geotextile used shall meet the following standards. All geotextile properties listed below are minimum average roll values (i.e., the test result for any sampled roll in a lot shall meet or exceed the values shown in [Table 4.2.3](#)):

<b>Table 4.2.3 Geotextile Standards</b>	
Polymeric Mesh AOS (ASTM D4751)	0.60 mm maximum for slit film woven (#30 sieve). 0.30 mm maximum for all other geotextile types (#50 sieve). 0.15 mm minimum for all fabric types (#100 sieve).
Water Permittivity (ASTM D4491)	0.02 sec <sup>-1</sup> minimum
Grab Tensile Strength (ASTM D4632)	180 lbs. Minimum for extra strength fabric. 100 lbs minimum for standard strength fabric.
Grab Tensile Strength (ASTM D4632)	30% maximum
Ultraviolet Resistance (ASTM D4355)	70% minimum

- Support standard strength fabrics with wire mesh, chicken wire, 2-inch x 2-inch wire, safety fence, or jute mesh to increase the strength of the fabric. Silt fence materials are available that have synthetic mesh backing attached.

- Filter fabric material shall contain ultraviolet ray inhibitors and stabilizers to provide a minimum of six months of expected usable construction life at a temperature range of 0°F. to 120°F.
- One-hundred percent biodegradable silt fence is available that is strong, long lasting, and can be left in place after the project is completed, if permitted by local regulations.
- Refer to [Figure 4.2.12](#) for standard silt fence details. Include the following standard Notes for silt fence on construction plans and specifications:
  1. The contractor shall install and maintain temporary silt fences at the locations shown in the Plans.
  2. Construct silt fences in areas of clearing, grading, or drainage prior to starting those activities.
  3. The silt fence shall have a 2-foot min. and a 2½-foot max. height above the original ground surface.
  4. The filter fabric shall be sewn together at the point of manufacture to form filter fabric lengths as required. Locate all sewn seams at support posts. Alternatively, two sections of silt fence can be overlapped, provided the Contractor can demonstrate, to the satisfaction of the Engineer, that the overlap is long enough and that the adjacent fence sections are close enough together to prevent silt laden water from escaping through the fence at the overlap.
  5. Attach the filter fabric on the up-slope side of the posts and secure with staples, wire, or in accordance with the manufacturer's recommendations. Attach the filter fabric to the posts in a manner that reduces the potential for tearing.
  6. Support the filter fabric with wire or plastic mesh, dependent on the properties of the geotextile selected for use. If wire or plastic mesh is used, fasten the mesh securely to the up-slope side of the posts with the filter fabric up-slope of the mesh.
  7. Mesh support, if used, shall consist of steel wire with a maximum mesh spacing of 2-inches, or a prefabricated polymeric mesh. The strength of the wire or polymeric mesh shall be equivalent to or greater than 180 lbs. grab tensile strength. The polymeric mesh must be as resistant to the same level of ultraviolet radiation as the filter fabric it supports.
  8. Bury the bottom of the filter fabric 4-inches min. below the ground surface. Backfill and tamp soil in place over the buried portion of the filter fabric, so that no flow can pass beneath the fence and scouring cannot occur. When wire or polymeric back-up support

mesh is used, the wire or polymeric mesh shall extend into the ground 3-inches min.

9. Drive or place the fence posts into the ground 18-inches min. A 12-inch min. depth is allowed if topsoil or other soft subgrade soil is not present and 18-inches cannot be reached. Increase fence post min. depths by 6 inches if the fence is located on slopes of 3H:1V or steeper and the slope is perpendicular to the fence. If required post depths cannot be obtained, the posts shall be adequately secured by bracing or guying to prevent overturning of the fence due to sediment loading.
  10. Use wood, steel or equivalent posts. The spacing of the support posts shall be a maximum of 6-feet. Posts shall consist of either:
    - Wood with dimensions of 2-inches by 2-inches wide min. and a 3-feet min. length. Wood posts shall be free of defects such as knots, splits, or gouges.
    - No. 6 steel rebar or larger.
    - ASTM A 120 steel pipe with a minimum diameter of 1-inch.
    - U, T, L, or C shape steel posts with a minimum weight of 1.35 lbs./ft.
    - Other steel posts having equivalent strength and bending resistance to the post sizes listed above.
  11. Locate silt fences on contour as much as possible, except at the ends of the fence, where the fence shall be turned uphill such that the silt fence captures the runoff water and prevents water from flowing around the end of the fence.
  12. If the fence must cross contours, with the exception of the ends of the fence, place gravel check dams perpendicular to the back of the fence to minimize concentrated flow and erosion. The slope of the fence line where contours must be crossed shall not be steeper than 3H:1V.
    - Gravel check dams shall be approximately 1-foot deep at the back of the fence. Gravel check dams shall be continued perpendicular to the fence at the same elevation until the top of the check dam intercepts the ground surface behind the fence.
    - Gravel check dams shall consist of crushed surfacing base course, gravel backfill for walls, or shoulder ballast. Gravel check dams shall be located every 10 feet along the fence where the fence must cross contours.
- Refer to [Figure 4.2.13](#) for slicing method details. Silt fence installation using the slicing method specifications:

1. The base of both end posts must be at least 2- to 4-inches above the top of the filter fabric on the middle posts for ditch checks to drain properly. Use a hand level or string level, if necessary, to mark base points before installation.
2. Install posts 3- to 4-feet apart in critical retention areas and 6- to 7-feet apart in standard applications.
3. Install posts 24-inches deep on the downstream side of the silt fence, and as close as possible to the filter fabric, enabling posts to support the filter fabric from upstream water pressure.
4. Install posts with the nipples facing away from the filter fabric.
5. Attach the filter fabric to each post with three ties, all spaced within the top 8-inches of the filter fabric. Attach each tie diagonally 45 degrees through the filter fabric, with each puncture at least 1-inch vertically apart. Each tie should be positioned to hang on a post nipple when tightening to prevent sagging.
6. Wrap approximately 6-inches of fabric around the end posts and secure with 3 ties.
7. No more than 24-inches of a 36-inch filter fabric is allowed above ground level.

Compact the soil immediately next to the filter fabric with the front wheel of the tractor, skid steer, or roller exerting at least 60 pounds per square inch. Compact the upstream side first and then each side twice for a total of four trips. Check and correct the silt fence installation for any deviation before compaction. Use a flat-bladed shovel to tuck fabric deeper into the ground if necessary.



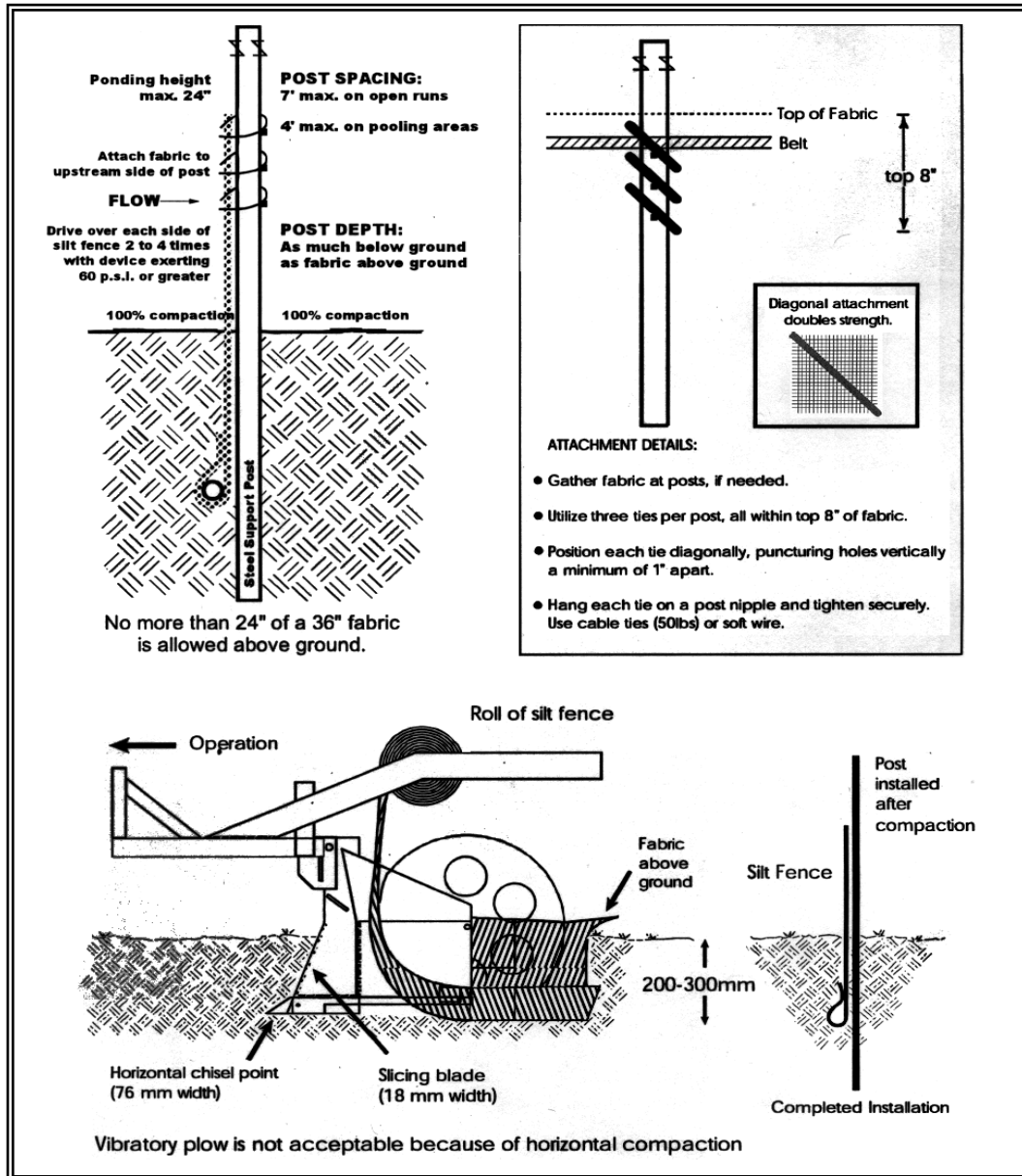

Figure 4.2.13 – Silt Fence Installation by Slicing Method

**Maintenance Standards**

- Repair any damage immediately.
- Intercept and convey all evident concentrated flows uphill of the silt fence to a sediment pond.
- Check the uphill side of the fence for signs of the fence clogging and acting as a barrier to flow and then causing channelization of flows parallel to the fence. If this occurs, replace the fence or remove the trapped sediment.

- Remove sediment deposits when the deposit reaches approximately one-third the height of the silt fence, or install a second silt fence.
- Replace filter fabric that has deteriorated due to ultraviolet breakdown.

## **BMP C234: Vegetated Strip**

### ***Purpose***

Vegetated strips reduce the transport of coarse sediment from a construction site by providing a temporary physical barrier to sediment and reducing the runoff velocities of overland flow.

### ***Conditions of Use***

- Vegetated strips may be used downslope of all disturbed areas.
- Vegetated strips are not intended to treat concentrated flows, nor are they intended to treat substantial amounts of overland flow. Any concentrated flows must be conveyed through the drainage system to a sediment pond. The only circumstance in which overland flow can be treated solely by a strip, rather than by a sediment pond, is when the following criteria are met (see [Table 4.2.4](#)):

<b>Table 4.2.4 Contributing Drainage Area for Vegetated Strips</b>		
<b>Average Contributing area Slope</b>	<b>Average Contributing area Percent Slope</b>	<b>Max Contributing area Flowpath Length</b>
1.5H:1V or flatter	67% or flatter	100 feet
2H:1V or flatter	50% or flatter	115 feet
4H:1V or flatter	25% or flatter	150 feet
6H:1V or flatter	16.7% or flatter	200 feet
10H:1V or flatter	10% or flatter	250 feet

### ***Design and Installation Specifications***

- The vegetated strip shall consist of a minimum of a 25-foot flowpath length continuous strip of dense vegetation with topsoil. Grass-covered, landscaped areas are generally not adequate because the volume of sediment overwhelms the grass. Ideally, vegetated strips shall consist of undisturbed native growth with a well-developed soil that allows for infiltration of runoff.
- The slope within the strip shall not exceed 4H:1V.
- The uphill boundary of the vegetated strip shall be delineated with clearing limits.

### ***Maintenance Standards***

- Any areas damaged by erosion or construction activity shall be seeded immediately and protected by mulch.
- If more than 5 feet of the original vegetated strip width has had vegetation removed or is being eroded, sod must be installed.
- If there are indications that concentrated flows are traveling across the buffer, surface water controls must be installed to reduce the flows

entering the buffer, or additional perimeter protection must be installed.

## **BMP C235: Wattles**

### ***Purpose***

Wattles are temporary erosion and sediment control barriers consisting of straw, compost, or other material that is wrapped in biodegradable tubular plastic or similar encasing material. They reduce the velocity and can spread the flow of rill and sheet runoff, and can capture and retain sediment. Wattles are typically 8 to 10 inches in diameter and 25 to 30 feet in length. Wattles are placed in shallow trenches and staked along the contour of disturbed or newly constructed slopes. See [Figure 4.2.14](#) for typical construction details. WSDOT Standard Plan I-30.30-00 also provides information on Wattles (<http://www.wsdot.wa.gov/Design/Standards/Plans.htm#SectionI>)

### ***Conditions of Use***

- Use wattles:
  - In disturbed areas that require immediate erosion protection.
  - On exposed soils during the period of short construction delays, or over winter months.
  - On slopes requiring stabilization until permanent vegetation can be established.
- The material used dictates the effectiveness period of the wattle. Generally, Wattles are typically effective for one to two seasons.
- Prevent rilling beneath wattles by properly entrenching and abutting wattles together to prevent water from passing between them.

### ***Design Criteria***

- Install wattles perpendicular to the flow direction and parallel to the slope contour.
- Narrow trenches should be dug across the slope on contour to a depth of 3- to 5-inches on clay soils and soils with gradual slopes. On loose soils, steep slopes, and areas with high rainfall, the trenches should be dug to a depth of 5- to 7- inches, or 1/2 to 2/3 of the thickness of the wattle.
- Start building trenches and installing wattles from the base of the slope and work up. Spread excavated material evenly along the uphill slope and compacted using hand tamping or other methods.
- Construct trenches at intervals of 10- to 25-feet depending on the steepness of the slope, soil type, and rainfall. The steeper the slope the closer together the trenches.
- Install the wattles snugly into the trenches and abut tightly end to end. Do not overlap the ends.
- Install stakes at each end of the wattle, and at 4-foot centers along entire length of wattle.

***Maintenance  
Standards***

- If required, install pilot holes for the stakes using a straight bar to drive holes through the wattle and into the soil.
- Wooden stakes should be approximately 3/4 x 3/4 x 24 inches min. Willow cuttings or 3/8-inch rebar can also be used for stakes.
- Stakes should be driven through the middle of the wattle, leaving 2 to 3 inches of the stake protruding above the wattle.
- Wattles may require maintenance to ensure they are in contact with soil and thoroughly entrenched, especially after significant rainfall on steep sandy soils.

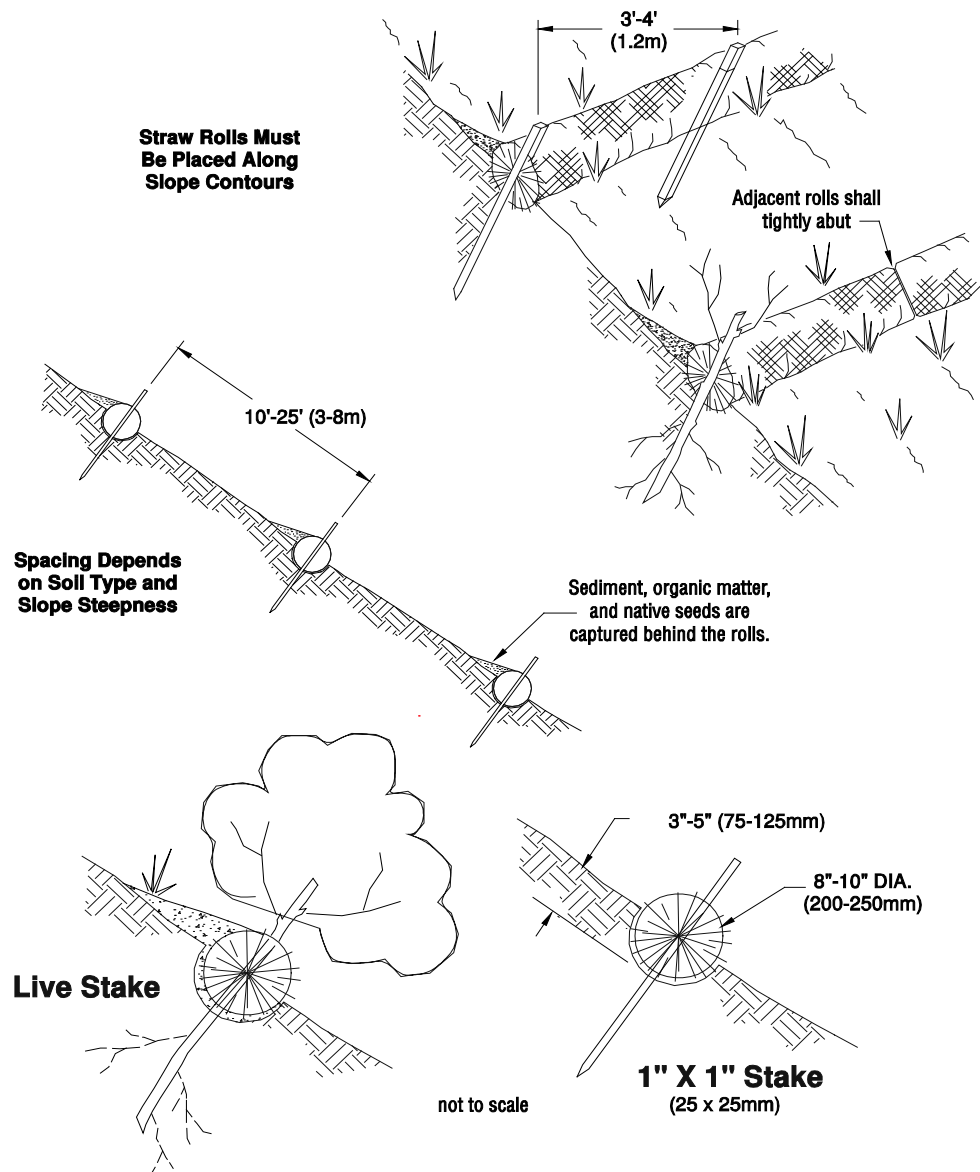

**NOTE:**  
 1. Straw roll installation requires the placement and secure staking of the roll in a trench, 3"-5" (75-125mm) deep, dug on contour. runoff must not be allowed to run under or around roll.

**Figure 4.2.14 – Wattles**

- Inspect the slope after significant storms and repair any areas where wattles are not tightly abutted or water has scoured beneath the wattles.

***Approved as Equivalent***

Ecology has approved products as able to meet the requirements of [BMP C235](#). The products did not pass through the Technology Assessment Protocol – Ecology (TAPE) process. Local jurisdictions may choose not to accept this product approved as equivalent, or may require additional testing prior to consideration for local use. The products are available for review on Ecology’s website at <http://www.ecy.wa.gov/programs/wq/stormwater/newtech/equivalent.html>

**BMP C236: Vegetative Filtration**

***Purpose***

Vegetative Filtration may be used in conjunction with [BMP C241](#) Temporary Sediment Ponds, [BMP C206](#) Level Spreader and a pumping system with surface intake to improve turbidity levels of stormwater discharges by filtering through existing vegetation where undisturbed forest floor duff layer or established lawn with thatch layer are present. Vegetative Filtration can also be used to infiltrate dewatering waste from foundations, vaults, and trenches as long as runoff does not occur.

***Conditions of Use***

- For every five acre of disturbed soil use one acre of grass field, farm pasture, or wooded area. Reduce or increase this area depending on project size, ground water table height, and other site conditions.
- Wetlands shall not be used for filtration.
- Do not use this BMP in areas with a high ground water table, or in areas that will have a high seasonal ground water table during the use of this BMP.
- This BMP may be less effective on soils that prevent the infiltration of the water, such as hard till.
- Using other effective source control measures throughout a construction site will prevent the generation of additional highly turbid water and may reduce the time period or area need for this BMP.
- Stop distributing water into the vegetated area if standing water or erosion results.

***Design Criteria***

- Find land adjacent to the project that has a vegetated field, preferably a farm field, or wooded area.
- If the project site does not contain enough vegetated field area consider obtaining permission from adjacent landowners (especially for farm fields).
- Install a pump and downstream distribution manifold depending on the project size. Generally, the main distribution line should reach 100 to 200-feet long (many large projects, or projects on tight soil, will

require systems that reach several thousand feet long with numerous branch lines off of the main distribution line).

- The manifold should have several valves, allowing for control over the distribution area in the field.
- Install several branches of 4” schedule 20, swaged-fit common septic tight-lined sewer line, or 6” fire hose, which can convey the turbid water out to various sections of the field. See [Figure 4.2.15](#).
- Determine the branch length based on the field area geography and number of branches. Typically, branches stretch from 200-feet to several thousand feet. Always, lay branches on contour with the slope.
- On uneven ground, sprinklers perform well. Space sprinkler heads so that spray patterns do not overlap.
- On relatively even surfaces, a level spreader using 4-inch perforated pipe may be used as an alternative option to the sprinkler head setup. Install drain pipe at the highest point on the field and at various lower elevations to ensure full coverage of the filtration area. Pipe should be placed with the holes up to allow for a gentle weeping of stormwater evenly out all holes. Leveling the pipe by staking and using sandbags may be required.
- To prevent the over saturation of the field area, rotate the use of branches or spray heads. Do this as needed based on monitoring the spray field.
- Monitor the spray field on a daily basis to ensure that over saturation of any portion of the field doesn’t occur at any time. The presence of standing puddles of water or creation of concentrated flows visually signify that over saturation of the field has occurred.
- Since the operator is handling contaminated water, physically monitor the vegetated spray field all the way down to the nearest surface water, or furthest spray area, to ensure that the water has not caused overland or concentrated flows, and has not created erosion around the spray nozzle.
- Monitoring usually needs to take place 3-5 times per day to ensure sheet-flow into state waters. Do not exceed water quality standards for turbidity.
- Ecology strongly recommends that a separate inspection log be developed, maintained and kept with the existing site logbook to aid the operator conducting inspections. This separate “Field Filtration Logbook” can also aid the facility in demonstrating compliance with permit conditions.

***Maintenance Standards***

- Inspect the spray nozzles daily, at a minimum, for leaks and plugging from sediment particles.
- If erosion, concentrated flows, or over saturation of the field occurs, rotate the use of branches or spray heads or move the branches to a new field location.
- Check all branches and the manifold for unintended leaks.

Flowpath Guidelines for Vegetative Filtration		
Average Slope	Average Area % Slope	Estimated Flowpath Length (ft)
1.5H:1V	67%	250
2H:1V	50%	200
4H:1V	25%	150
6H:1V	16.7%	115
10H:1V	10%	100



**Figure 4.2.15 – Manifold and Braches in a wooded, vegetated spray field**



## **BMP C240: Sediment Trap**

**Purpose** A sediment trap is a small temporary ponding area with a gravel outlet used to collect and store sediment from sites cleared and/or graded during construction. Sediment traps, along with other perimeter controls, shall be installed before any land disturbance takes place in the drainage area.

**Conditions of Use** Prior to leaving a construction site, stormwater runoff must pass through a sediment pond or trap or other appropriate sediment removal best management practice. Non-engineered sediment traps may be used on-site prior to an engineered sediment trap or sediment pond to provide additional sediment removal capacity.

It is intended for use on sites where the tributary drainage area is less than 3 acres, with no unusual drainage features, and a projected build-out time of six months or less. The sediment trap is a temporary measure (with a design life of approximately 6 months) and shall be maintained until the site area is permanently protected against erosion by vegetation and/or structures.

Sediment traps and ponds are only effective in removing sediment down to about the medium silt size fraction. Runoff with sediment of finer grades (fine silt and clay) will pass through untreated, emphasizing the need to control erosion to the maximum extent first.

Whenever possible, sediment-laden water shall be discharged into on-site, relatively level, vegetated areas (see [BMP C234 – Vegetated Strip](#)). This is the only way to effectively remove fine particles from runoff unless chemical treatment or filtration is used. This can be particularly useful after initial treatment in a sediment trap or pond. The areas of release must be evaluated on a site-by-site basis in order to determine appropriate locations for and methods of releasing runoff. Vegetated wetlands shall not be used for this purpose. Frequently, it may be possible to pump water from the collection point at the downhill end of the site to an upslope vegetated area. Pumping shall only augment the treatment system, not replace it, because of the possibility of pump failure or runoff volume in excess of pump capacity.

All projects that are constructing permanent facilities for runoff quantity control should use the rough-graded or final-graded permanent facilities for traps and ponds. This includes combined facilities and infiltration facilities. When permanent facilities are used as temporary sedimentation facilities, the surface area requirement of a sediment trap or pond must be met. If the surface area requirements are larger than the surface area of the permanent facility, then the trap or pond shall be enlarged to comply with the surface area requirement. The permanent pond shall also be divided into two cells as required for sediment ponds.

Either a permanent control structure or the temporary control structure (described in [BMP C241](#), Temporary Sediment Pond) can be used. If a permanent control structure is used, it may be advisable to partially restrict the lower orifice with gravel to increase residence time while still allowing dewatering of the pond. A shut-off valve may be added to the control structure to allow complete retention of stormwater in emergency situations. In this case, an emergency overflow weir must be added.

A skimmer may be used for the sediment trap outlet if approved by the Local Permitting Authority.

***Design and  
Installation  
Specifications***

- See [Figures 4.2.16](#) and [4.2.17](#) for details.
- If permanent runoff control facilities are part of the project, they should be used for sediment retention.
- To determine the sediment trap geometry, first calculate the design surface area (SA) of the trap, measured at the invert of the weir. Use the following equation:

$$SA = FS(Q_2/V_s)$$

where

$Q_2$  = Design inflow based on the peak discharge from the developed 2-year runoff event from the contributing drainage area as computed in the hydrologic analysis. The 10-year peak flow shall be used if the project size, expected timing and duration of construction, or downstream conditions warrant a higher level of protection. If no hydrologic analysis is required, the Rational Method may be used.

$V_s$  = The settling velocity of the soil particle of interest. The 0.02 mm (medium silt) particle with an assumed density of 2.65 g/cm<sup>3</sup> has been selected as the particle of interest and has a settling velocity ( $V_s$ ) of 0.00096 ft/sec.

$FS$  = A safety factor of 2 to account for non-ideal settling.

Therefore, the equation for computing surface area becomes:

$$SA = 2 \times Q_2 / 0.00096 \text{ or}$$

2080 square feet per cfs of inflow

Note: Even if permanent facilities are used, they must still have a surface area that is at least as large as that derived from the above formula. If they do not, the pond must be enlarged.

- To aid in determining sediment depth, all sediment traps shall have a staff gauge with a prominent mark 1-foot above the bottom of the trap.

- Sediment traps may not be feasible on utility projects due to the limited work space or the short-term nature of the work. Portable tanks may be used in place of sediment traps for utility projects.
- Sediment shall be removed from the trap when it reaches 1-foot in depth.
- Any damage to the pond embankments or slopes shall be repaired.

**Maintenance Standards**

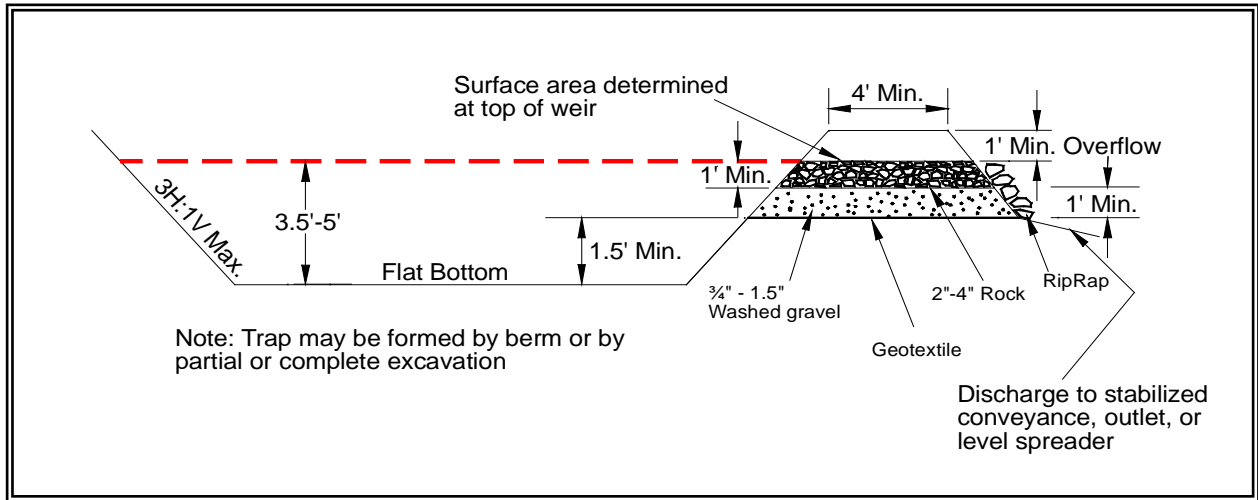

**Figure 4.2.16 – Cross Section of Sediment Trap**

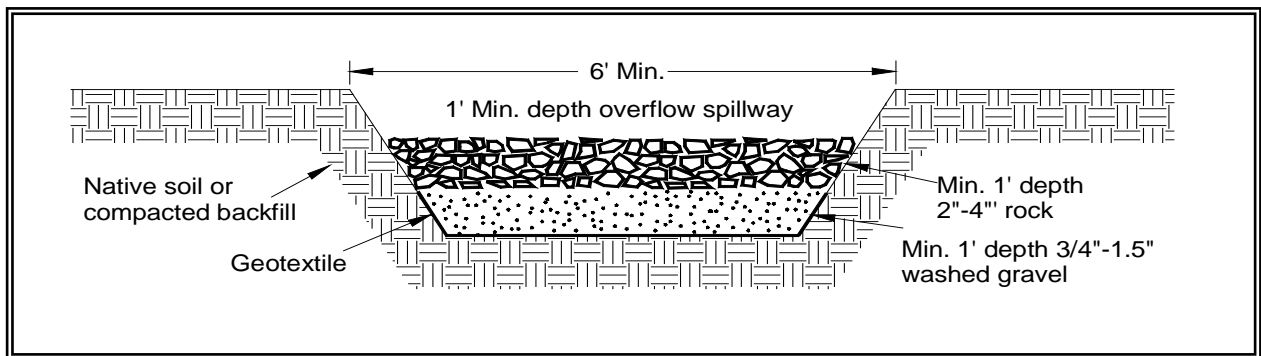

**Figure 4.2.17 – Sediment Trap Outlet**

## **BMP C241: Temporary Sediment Pond**

**Purpose** Sediment ponds remove sediment from runoff originating from disturbed areas of the site. Sediment ponds are typically designed to remove sediment no smaller than medium silt (0.02 mm). Consequently, they usually reduce turbidity only slightly.

**Conditions of Use** Prior to leaving a construction site, stormwater runoff must pass through a sediment pond or other appropriate sediment removal best management practice.

A sediment pond shall be used where the contributing drainage area is 3 acres or more. Ponds must be used in conjunction with erosion control practices to reduce the amount of sediment flowing into the basin.

### **Design and Installation Specifications**

- Sediment basins must be installed only on sites where failure of the structure would not result in loss of life, damage to homes or buildings, or interruption of use or service of public roads or utilities. Also, sediment traps and ponds are attractive to children and can be very dangerous. Compliance with local ordinances regarding health and safety must be addressed. If fencing of the pond is required, the type of fence and its location shall be shown on the ESC plan.
- Structures having a maximum storage capacity at the top of the dam of 10 acre-ft (435,600 ft<sup>3</sup>) or more are subject to the Washington Dam Safety Regulations ([Chapter 173-175 WAC](#)).
- See [Figures 4.2.18](#), [4.2.19](#), and [4.2.20](#) for details.
- If permanent runoff control facilities are part of the project, they should be used for sediment retention. The surface area requirements of the sediment basin must be met. This may require temporarily enlarging the permanent basin to comply with the surface area requirements. The permanent control structure must be temporarily replaced with a control structure that only allows water to leave the pond from the surface or by pumping. The permanent control structure must be installed after the site is fully stabilized. .
- Use of infiltration facilities for sedimentation basins during construction tends to clog the soils and reduce their capacity to infiltrate. If infiltration facilities are to be used, the sides and bottom of the facility must only be rough excavated to a minimum of 2 feet above final grade. Final grading of the infiltration facility shall occur only when all contributing drainage areas are fully stabilized. The infiltration pretreatment facility should be fully constructed and used with the sedimentation basin to help prevent clogging.
- Determining Pond Geometry  
Obtain the discharge from the hydrologic calculations of the peak flow for the 2-year runoff event ( $Q_2$ ). The 10-year peak flow shall be used if

the project size, expected timing and duration of construction, or downstream conditions warrant a higher level of protection. If no hydrologic analysis is required, the Rational Method may be used.

Determine the required surface area at the top of the riser pipe with the equation:

$$SA = 2 \times Q_2 / 0.00096 \quad \text{or} \\ 2080 \text{ square feet per cfs of inflow}$$

See [BMP C240](#) for more information on the derivation of the surface area calculation.

The basic geometry of the pond can now be determined using the following design criteria:

- Required surface area SA (from Step 2 above) at top of riser.
- Minimum 3.5-foot depth from top of riser to bottom of pond.
- Maximum 3H:1V interior side slopes and maximum 2H:1V exterior slopes. The interior slopes can be increased to a maximum of 2H:1V if fencing is provided at or above the maximum water surface.
- One foot of freeboard between the top of the riser and the crest of the emergency spillway.
- Flat bottom.
- Minimum 1-foot deep spillway.
- Length-to-width ratio between 3:1 and 6:1.
- Sizing of Discharge Mechanisms.

The outlet for the basin consists of a combination of principal and emergency spillways. These outlets must pass the peak runoff expected from the contributing drainage area for a 100-year storm. If, due to site conditions and basin geometry, a separate emergency spillway is not feasible, the principal spillway must pass the entire peak runoff expected from the 100-year storm. However, an attempt to provide a separate emergency spillway should always be made. The runoff calculations should be based on the site conditions during construction. The flow through the dewatering orifice cannot be utilized when calculating the 100-year storm elevation because of its potential to become clogged; therefore, available spillway storage must begin at the principal spillway riser crest.

The principal spillway designed by the procedures contained in this standard will result in some reduction in the peak rate of runoff. However, the riser outlet design will not adequately control the basin discharge to the predevelopment discharge limitations as stated in Minimum Requirement #7: Flow Control. However, if the basin for a permanent stormwater detention pond is used for a temporary

sedimentation basin, the control structure for the permanent pond can be used to maintain predevelopment discharge limitations. The size of the basin, the expected life of the construction project, the anticipated downstream effects and the anticipated weather conditions during construction, should be considered to determine the need of additional discharge control. See [Figure 4.2.21](#) for riser inflow curves.

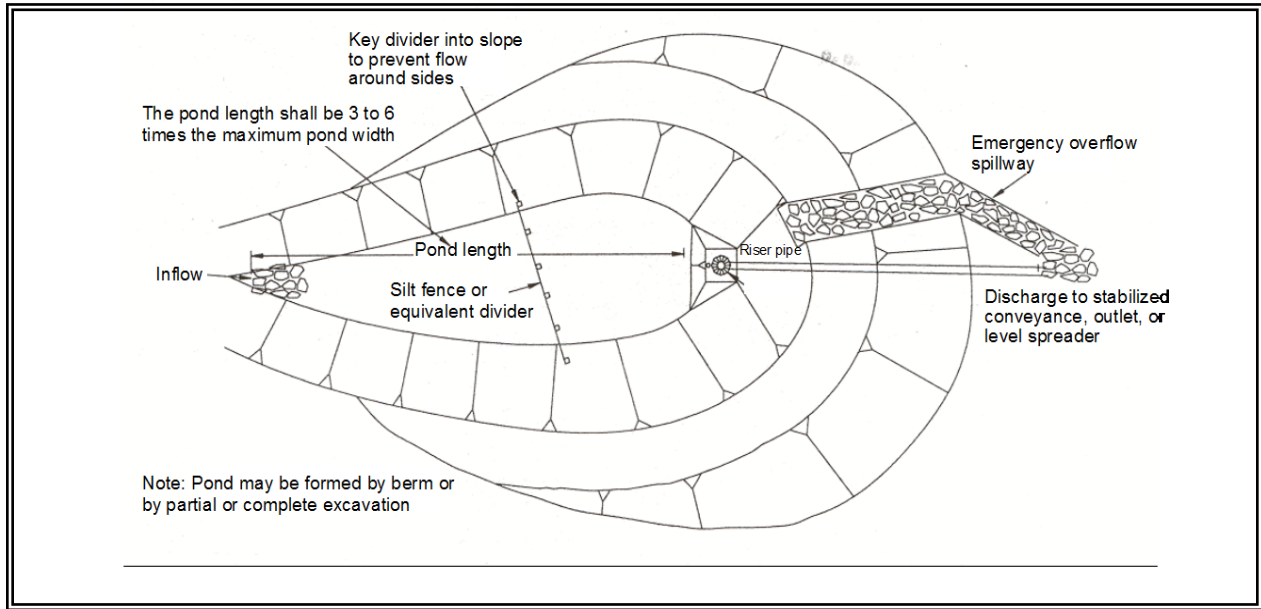

**Figure 4.2.18 – Sediment Pond Plan View**

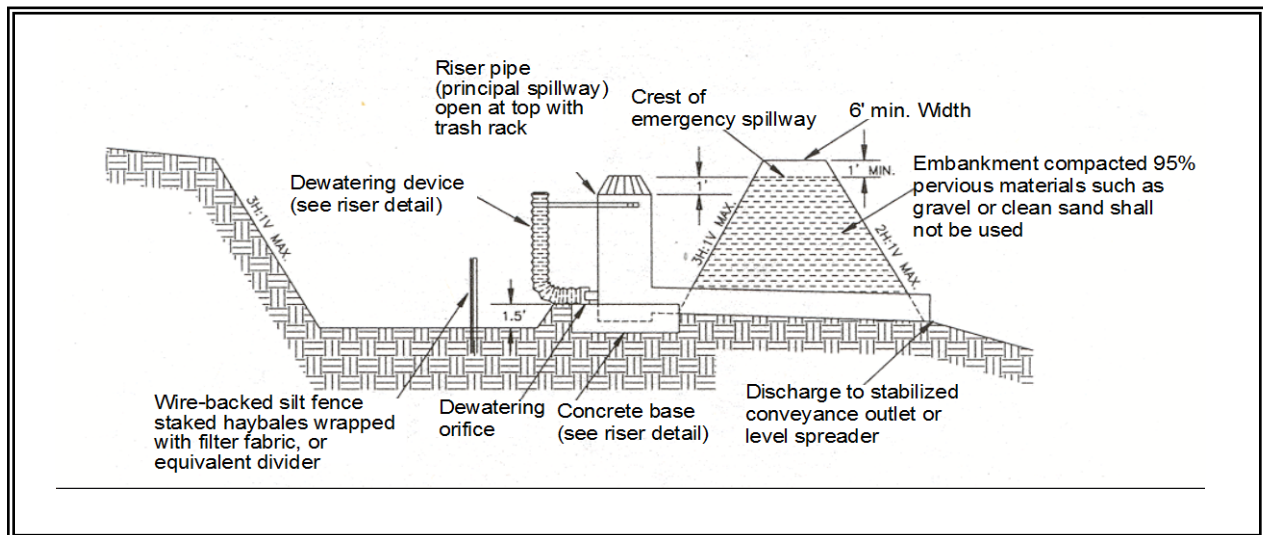

**Figure 4.2.19 – Sediment Pond Cross Section**

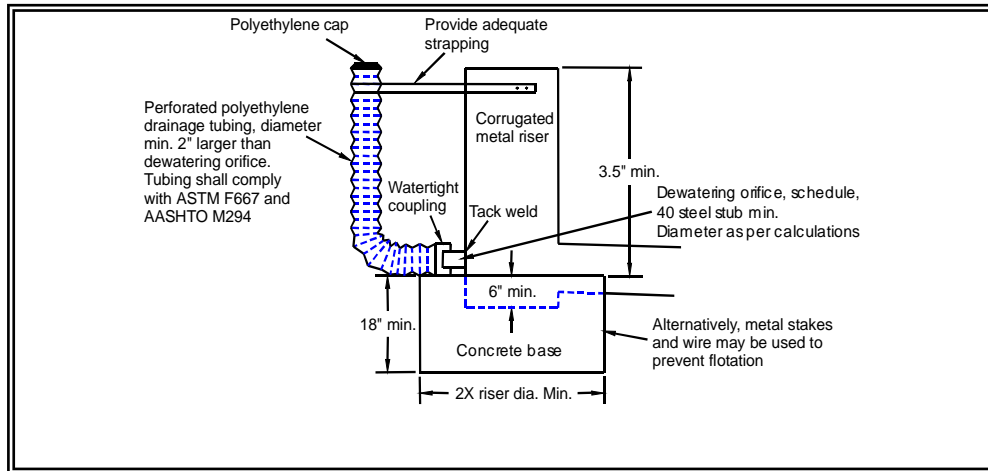

**Figure 4.2.20 – Sediment Pond Riser Detail**

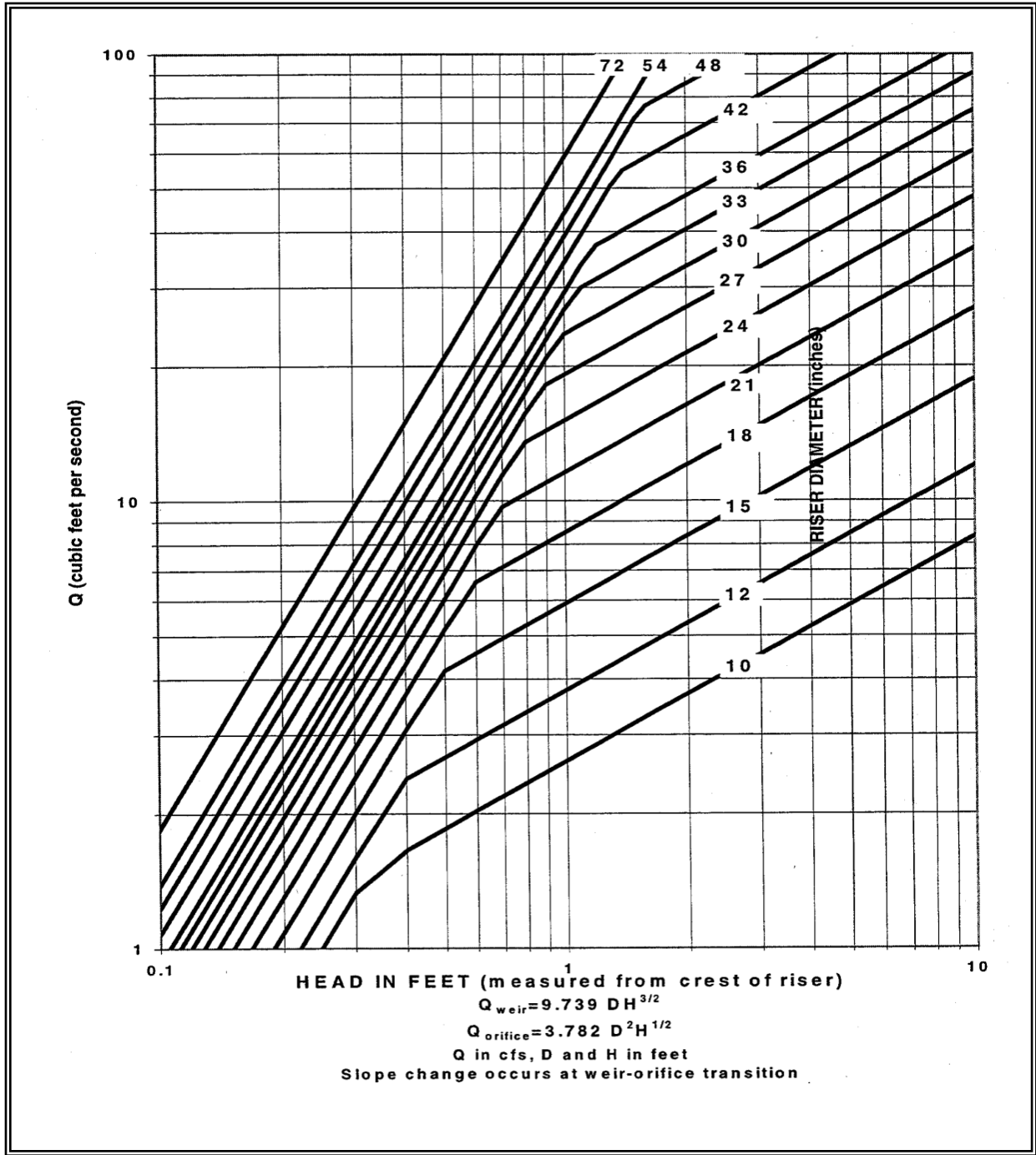

Figure 4.2.21 – Riser Inflow Curves



**Principal Spillway:** Determine the required diameter for the principal spillway (riser pipe). The diameter shall be the minimum necessary to pass the site's 15-minute, 10-year flowrate. If using the Western Washington Hydrology Model (WWHM), Version 2 or 3, design flow is the 10-year (1 hour) flow for the developed (unmitigated) site, multiplied by a factor of 1.6. Use Figure 4.2.21 to determine this diameter ( $h = 1$ -foot). *Note: A permanent control structure may be used instead of a temporary riser.*

**Emergency Overflow Spillway:** Determine the required size and design of the emergency overflow spillway for the developed 100-year peak flow using the method contained in Volume III.

**Dewatering Orifice:** Determine the size of the dewatering orifice(s) (minimum 1-inch diameter) using a modified version of the discharge equation for a vertical orifice and a basic equation for the area of a circular orifice. Determine the required area of the orifice with the following equation:

$$A_o = \frac{A_s (2h)^{0.5}}{0.6 \times 3600 T g^{0.5}}$$

where  $A_o$  = orifice area (square feet)  
 $A_s$  = pond surface area (square feet)  
 $h$  = head of water above orifice (height of riser in feet)  
 $T$  = dewatering time (24 hours)  
 $g$  = acceleration of gravity (32.2 feet/second<sup>2</sup>)

Convert the required surface area to the required diameter  $D$  of the orifice:

$$D = 24 \times \sqrt{\frac{A_o}{\pi}} = 13.54 \times \sqrt{A_o}$$

The vertical, perforated tubing connected to the dewatering orifice must be at least 2 inches larger in diameter than the orifice to improve flow characteristics. The size and number of perforations in the tubing should be large enough so that the tubing does not restrict flow. The orifice should control the flow rate.

- **Additional Design Specifications**

The pond shall be divided into two roughly equal volume cells by a permeable divider that will reduce turbulence while allowing movement of water between cells. The divider shall be at least one-half the height of the riser and a minimum of one foot below the top of the riser. Wire-backed, 2- to 3-foot high, extra strength filter fabric supported by treated 4"x4"s can be used as a divider. Alternatively, staked straw bales wrapped with filter fabric (geotextile) may be used. If the pond is more than 6 feet deep, a different mechanism must be proposed. A riprap embankment is one acceptable method of

separation for deeper ponds. Other designs that satisfy the intent of this provision are allowed as long as the divider is permeable, structurally sound, and designed to prevent erosion under or around the barrier.

To aid in determining sediment depth, one-foot intervals shall be prominently marked on the riser.

If an embankment of more than 6 feet is proposed, the pond must comply with the criteria contained in Volume III regarding dam safety for detention BMPs.

- The most common structural failure of sedimentation basins is caused by piping. Piping refers to two phenomena: (1) water seeping through fine-grained soil, eroding the soil grain by grain and forming pipes or tunnels; and, (2) water under pressure flowing upward through a granular soil with a head of sufficient magnitude to cause soil grains to lose contact and capability for support.

The most critical construction sequences to prevent piping will be:

1. Tight connections between riser and barrel and other pipe connections.
2. Adequate anchoring of riser.
3. Proper soil compaction of the embankment and riser footing.
4. Proper construction of anti-seep devices.

***Maintenance Standards***

- Sediment shall be removed from the pond when it reaches 1-foot in depth.
- Any damage to the pond embankments or slopes shall be repaired.

**BMP C250: Construction Stormwater Chemical Treatment**

***Purpose***

This BMP applies when using stormwater chemicals in batch treatment or flow-through treatment.

Turbidity is difficult to control once fine particles are suspended in stormwater runoff from a construction site. Sedimentation ponds are effective at removing larger particulate matter by gravity settling, but are ineffective at removing smaller particulates such as clay and fine silt. Traditional erosion and sediment control BMPs may not be adequate to ensure compliance with the water quality standards for turbidity in receiving water.

Chemical treatment can reliably provide exceptional reductions of turbidity and associated pollutants. Chemical treatment may be required to meet turbidity stormwater discharge requirements, especially when construction is to proceed through the wet season.

***Conditions of Use***

Formal written approval from Ecology is required for the use of chemical treatment regardless of site size. The Local Permitting Authority may also

***Design and  
Installation  
Specifications***

require review and approval. When approved, the chemical treatment systems must be included in the Construction Stormwater Pollution Prevention Plan (SWPPP).

See [Appendix II-B](#) for background information on chemical treatment.

**Criteria for Chemical Treatment Product Use:** Chemically treated stormwater discharged from construction sites must be nontoxic to aquatic organisms. The Chemical Technology Assessment Protocol (CTAPE) must be used to evaluate chemicals proposed for stormwater treatment. Only chemicals approved by Ecology under the CTAPE may be used for stormwater treatment. The approved chemicals, their allowable application techniques (batch treatment or flow-through treatment), allowable application rates, and conditions of use can be found at the Department of Ecology Emerging Technologies website: <http://www.ecy.wa.gov/programs/wq/stormwater/newtech/technologies.html>.

**Treatment System Design Considerations:** The design and operation of a chemical treatment system should take into consideration the factors that determine optimum, cost-effective performance. It is important to recognize the following:

- Only Ecology approved chemicals may be used and must follow approved dose rate.
- The pH of the stormwater must be in the proper range for the polymers to be effective, which is typically 6.5 to 8.5
- The coagulant must be mixed rapidly into the water to ensure proper dispersion.
- A flocculation step is important to increase the rate of settling, to produce the lowest turbidity, and to keep the dosage rate as low as possible.
- Too little energy input into the water during the flocculation phase results in flocs that are too small and/or insufficiently dense. Too much energy can rapidly destroy floc as it is formed.
- Care must be taken in the design of the withdrawal system to minimize outflow velocities and to prevent floc discharge. Discharge from a batch treatment system should be directed through a physical filter such as a vegetated swale that would catch any unintended floc discharge. Currently, flow-through systems always discharge through the chemically enhanced sand filtration system.
- System discharge rates must take into account downstream conveyance integrity.

### **Polymer Batch Treatment Process Description:**

A batch chemical treatment system consists of the stormwater collection system (either temporary diversion or the permanent site drainage system), a storage pond, pumps, a chemical feed system, treatment cells, and interconnecting piping.

The batch treatment system shall use a minimum of two lined treatment cells in addition to an untreated stormwater storage pond. Multiple treatment cells allow for clarification of treated water while other cells are being filled or emptied. Treatment cells may be ponds or tanks. Ponds with constructed earthen embankments greater than six feet high or which impound more than 10 acre-feet require special engineering analyses. The Ecology Dam Safety Section has specific design criteria for dams in Washington State (see <http://www.ecy.wa.gov/programs/wr/dams/GuidanceDocs.html> ).

Stormwater is collected at interception point(s) on the site and is diverted by gravity or by pumping to an untreated stormwater storage pond or other untreated stormwater holding area. The stormwater is stored until treatment occurs. It is important that the holding pond be large enough to provide adequate storage.

The first step in the treatment sequence is to check the pH of the stormwater in the untreated stormwater storage pond. The pH is adjusted by the application of carbon dioxide or a base until the stormwater in the storage pond is within the desired pH range, 6.5 to 8.5. When used, carbon dioxide is added immediately downstream of the transfer pump. Typically sodium bicarbonate (baking soda) is used as a base, although other bases may be used. When needed, base is added directly to the untreated stormwater storage pond. The stormwater is recirculated with the treatment pump to provide mixing in the storage pond. Initial pH adjustments should be based on daily bench tests. Further pH adjustments can be made at any point in the process.

Once the stormwater is within the desired pH range (dependant on polymer being used), the stormwater is pumped from the untreated stormwater storage pond to a treatment cell as polymer is added. The polymer is added upstream of the pump to facilitate rapid mixing.

After polymer addition, the water is kept in a lined treatment cell for clarification of the sediment-floc. In a batch mode process, clarification typically takes from 30 minutes to several hours. Prior to discharge samples are withdrawn for analysis of pH, flocculent chemical concentration, and turbidity. If both are acceptable, the treated water is discharged.

Several configurations have been developed to withdraw treated water from the treatment cell. The original configuration is a device that withdraws the treated water from just beneath the water surface using a

float with adjustable struts that prevent the float from settling on the cell bottom. This reduces the possibility of picking up sediment-floc from the bottom of the pond. The struts are usually set at a minimum clearance of about 12 inches; that is, the float will come within 12 inches of the bottom of the cell. Other systems have used vertical guides or cables which constrain the float, allowing it to drift up and down with the water level. More recent designs have an H-shaped array of pipes, set on the horizontal.

This scheme provides for withdrawal from four points rather than one. This configuration reduces the likelihood of sucking settled solids from the bottom. It also reduces the tendency for a vortex to form. Inlet diffusers, a long floating or fixed pipe with many small holes in it, are also an option.

Safety is a primary concern. Design should consider the hazards associated with operations, such as sampling. Facilities should be designed to reduce slip hazards and drowning. Tanks and ponds should have life rings, ladders, or steps extending from the bottom to the top.

#### **Polymer Batch Treatment Process Description:**

At a minimum, a flow-through chemical treatment system consists of the stormwater collection system (either temporary diversion or the permanent site drainage system), an untreated stormwater storage pond, and the chemically enhanced sand filtration system.

Stormwater is collected at interception point(s) on the site and is diverted by gravity or by pumping to an untreated stormwater storage pond or other untreated stormwater holding area. The stormwater is stored until treatment occurs. It is important that the holding pond be large enough to provide adequate storage.

Stormwater is then pumped from the untreated stormwater storage pond to the chemically enhanced sand filtration system where polymer is added. Adjustments to pH may be necessary before chemical addition. The sand filtration system continually monitors the stormwater for turbidity and pH. If the discharge water is ever out of an acceptable range for turbidity or pH, the water is recycled to the untreated stormwater pond where it can be retreated.

*For batch treatment and flow-through treatment*, the following equipment should be located in a lockable shed:

- The chemical injector.
- Secondary containment for acid, caustic, buffering compound, and treatment chemical.
- Emergency shower and eyewash.
- Monitoring equipment which consists of a pH meter and a turbidimeter.

### **System Sizing:**

Certain sites are required to implement flow control for the developed sites. These sites must also control stormwater release rates during construction. Generally, these are sites that discharge stormwater directly, or indirectly, through a conveyance system, into a fresh water. System sizing is dependent on flow control requirements.

### **Sizing Criteria for Batch Treatment Systems for Flow Control Exempt Water Bodies:**

The total volume of the untreated stormwater storage pond and treatment ponds or tanks must be large enough to treat stormwater that is produced during multiple day storm events. It is recommended that at a minimum the untreated stormwater storage pond be sized to hold 1.5 times the runoff volume of the 10-year, 24-hour storm event. Bypass should be provided around the chemical treatment system to accommodate extreme storm events. Runoff volume shall be calculated using the methods presented in Volume 3, Chapter 2. Worst-case land cover conditions (i.e., producing the most runoff) should be used for analyses (in most cases, this would be the land cover conditions just prior to final landscaping).

Primary settling should be encouraged in the untreated stormwater storage pond. A forebay with access for maintenance may be beneficial.

There are two opposing considerations in sizing the treatment cells. A larger cell is able to treat a larger volume of water each time a batch is processed. However, the larger the cell the longer the time required to empty the cell. A larger cell may also be less effective at flocculation and therefore require a longer settling time. The simplest approach to sizing the treatment cell is to multiply the allowable discharge flow rate times the desired drawdown time. A 4-hour drawdown time allows one batch per cell per 8-hour work period, given 1 hour of flocculation followed by two hours of settling.

If the discharge is directly to a flow control exempt receiving water listed in Appendix I-E of Volume I or to an infiltration system, there is no discharge flow limit.

Ponds sized for flow control water bodies must at a minimum meet the sizing criteria for flow control exempt waters.

### **Sizing Criteria for Flow-Through Treatment Systems for Flow Control Exempt Water Bodies:**

When sizing storage ponds or tanks for flow-through systems for flow control exempt water bodies, the treatment system capacity should be a factor. The untreated stormwater storage pond or tank should be sized to hold 1.5 times the runoff volume of the 10-year, 24-hour storm event minus the treatment system flowrate for an 8-hour period. For a chitosan-enhanced sand filtration system, the treatment system flowrate should be sized using a hydraulic loading rate between 6-8 gpm/ft<sup>2</sup>. Other hydraulic

loading rates may be more appropriate for other systems. Bypass should be provided around the chemical treatment system to accommodate extreme storms. Runoff volume shall be calculated using the methods presented in Volume 3, Chapter 2. Worst-case land cover conditions (i.e., producing the most runoff) should be used for analyses (in most cases, this would be the land cover conditions just prior to final landscaping).

### **Sizing Criteria for Flow Control Water Bodies:**

Sites that must implement flow control for the developed site condition must also control stormwater release rates during construction. Construction site stormwater discharges shall not exceed the discharge durations of the pre-developed condition for the range of pre-developed discharge rates from ½ of the 2-year flow through the 10-year flow as predicted by an approved continuous runoff model. The pre-developed condition to be matched shall be the land cover condition immediately prior to the development project. This restriction on release rates can affect the size of the storage pond and treatment cells.

The following is how WWHM can be used to determine the release rates from the chemical treatment systems:

1. Determine the pre-developed flow durations to be matched by entering the existing land use area under the “Pre-developed” scenario in WWHM. The default flow range is from ½ of the 2-year flow through the 10-year flow.
2. Enter the post developed land use area in the “Developed Unmitigated” scenario in WWHM.
3. Copy the land use information from the “Developed Unmitigated” to “Developed Mitigated” scenario.
4. While in the “Developed Mitigated” scenario, add a pond element under the basin element containing the post-developed land use areas. This pond element represents information on the available untreated stormwater storage and discharge from the chemical treatment system. In cases where the discharge from the chemical treatment system is controlled by a pump, a stage/storage/discharge (SSD) table representing the pond must be generated outside WWHM and imported into WWHM. WWHM can route the runoff from the post-developed condition through this SSD table (the pond) and determine compliance with the flow duration standard. This would be an iterative design procedure where if the initial SSD table proved to be inadequate, the designer would have to modify the SSD table outside WWHM and re-import in WWHM and route the runoff through it again. The iteration will continue until a pond that complies with the flow duration standard is correctly sized.

Notes on SSD table characteristics:

- The pump discharge rate would likely be initially set at just below  $\frac{1}{2}$  of the 2-year flow from the pre-developed condition. As runoff coming into the untreated stormwater storage pond increases and the available untreated stormwater storage volume gets used up, it would be necessary to increase the pump discharge rate above  $\frac{1}{2}$  of the 2-year. The increase(s) above  $\frac{1}{2}$  of the 2-year must be such that they provide some relief to the untreated stormwater storage needs but at the same time will not cause violations of the flow duration standard at the higher flows. The final design SSD table will identify the appropriate pumping rates and the corresponding stage and storages.
  - When building such a flow control system, the design must ensure that any automatic adjustments to the pumping rates will be as a result of changes to the available storage in accordance with the final design SSD table.
5. It should be noted that the above procedures would be used to meet the flow control requirements. The chemical treatment system must be able to meet the runoff treatment requirements. It is likely that the discharge flow rate of  $\frac{1}{2}$  of the 2-year or more may exceed the treatment capacity of the system. If that is the case, the untreated stormwater discharge rate(s) (i.e., influent to the treatment system) must be reduced to allow proper treatment. Any reduction in the flows would likely result in the need for a larger untreated stormwater storage volume.

If the discharge is to a municipal storm drainage system, the allowable discharge rate may be limited by the capacity of the public system. It may be necessary to clean the municipal storm drainage system prior to the start of the discharge to prevent scouring solids from the drainage system. If the municipal storm drainage system discharges to a water body not on the flow control exempt list, the project site is subject to flow control requirements. Obtain permission from the owner of the collection system before discharging to it.

If system design does not allow you to discharge at the slower rates as described above and if the site has a retention or detention pond that will serve the planned development, the discharge from the treatment system may be directed to the permanent retention/detention pond to comply with the flow control requirement. In this case, the untreated stormwater storage pond and treatment system will be sized according to the sizing criteria for flow-through treatment systems for flow control exempt water bodies described earlier except all discharge (water passing through the treatment system and stormwater bypassing the treatment system) will be directed into the permanent retention/detention pond. If site constraints make locating the untreated stormwater storage pond difficult, the permanent retention/detention pond may be divided to serve as the untreated stormwater



## ***Maintenance Standards***

storage pond and the post-treatment flow control pond. A berm or barrier must be used in this case so the untreated water does not mix with the treated water. Both untreated stormwater storage requirements, and adequate post-treatment flow control must be achieved. The post-treatment flow control pond's revised dimensions must be entered into the WWHM and the WWHM must be run to confirm compliance with the flow control requirement.

**Monitoring:** At a minimum, the following monitoring shall be conducted. Test results shall be recorded on a daily log kept on site. Additional testing may be required by the NPDES permit based on site conditions.

### Operational Monitoring:

- Total volume treated and discharged.
- Flow must be continuously monitored and recorded at not greater than 15-minute intervals.
- Type and amount of chemical used for pH adjustment.
- Amount of polymer used for treatment.
- Settling time.

### Compliance Monitoring:

- Influent and effluent pH, flocculent chemical concentration, and turbidity must be continuously monitored and recorded at not greater than 15-minute intervals. pH and turbidity of the receiving water.

### Biomonitoring:

Treated stormwater must be non-toxic to aquatic organisms. Treated stormwater must be tested for aquatic toxicity or residual chemicals. Frequency of biomonitoring will be determined by Ecology.

Residual chemical tests must be approved by Ecology prior to their use.

If testing treated stormwater for aquatic toxicity, you must test for acute (lethal) toxicity. Bioassays shall be conducted by a laboratory accredited by Ecology, unless otherwise approved by Ecology. Acute toxicity tests shall be conducted per the CTAPE protocol.

**Discharge Compliance: Prior to discharge, treated stormwater must be sampled and tested for compliance with pH, flocculent chemical concentration, and turbidity limits.** These limits may be established by the Construction Stormwater General Permit or a site-specific discharge permit. Sampling and testing for other pollutants may also be necessary at some sites. pH must be within the range of 6.5 to 8.5 standard units and not cause a change in the pH of the receiving water of more than 0.2 standard units. Treated stormwater samples and measurements shall be taken from the discharge pipe or another location representative of the nature of the treated stormwater discharge. Samples used for determining compliance with the water quality standards in the receiving water shall

not be taken from the treatment pond prior to decanting. Compliance with the water quality standards is determined in the receiving water.

**Operator Training:** Each contractor who intends to use chemical treatment shall be trained by an experienced contractor. Each site using chemical treatment must have an operator trained and certified by an organization approved by Ecology.

**Standard BMPs:** Surface stabilization BMPs should be implemented on site to prevent significant erosion. All sites shall use a truck wheel wash to prevent tracking of sediment off site.

**Sediment Removal and Disposal:**

- Sediment shall be removed from the storage or treatment cells as necessary. Typically, sediment removal is required at least once during a wet season and at the decommissioning of the cells. Sediment remaining in the cells between batches may enhance the settling process and reduce the required chemical dosage.
- Sediment that is known to be non-toxic may be incorporated into the site away from drainages.

**BMP C251: Construction Stormwater Filtration**

*Purpose*

Filtration removes sediment from runoff originating from disturbed areas of the site.

*Background Information:*

Filtration with sand media has been used for over a century to treat water and wastewater. The use of sand filtration for treatment of stormwater has developed recently, generally to treat runoff from streets, parking lots, and residential areas. The application of filtration to construction stormwater treatment is currently under development.

*Conditions of Use*

Traditional BMPs used to control soil erosion and sediment loss from sites under development may not be adequate to ensure compliance with the water quality standard for turbidity in the receiving water. Filtration may be used in conjunction with gravity settling to remove sediment as small as fine silt (0.5 µm). The reduction in turbidity will be dependent on the particle size distribution of the sediment in the stormwater. In some circumstances, sedimentation and filtration may achieve compliance with the water quality standard for turbidity.

The use of construction stormwater filtration does not require approval from Ecology as long as treatment chemicals are not used. Filtration in conjunction with polymer treatment requires testing under the Chemical Technology Assessment Protocol – Ecology (CTAPE) before it can be initiated. Approval from the appropriate regional Ecology office must be obtained at each site where polymers use is proposed prior to use. For more guidance on stormwater chemical treatment see [BMP C250](#).

***Design and  
Installation  
Specifications***

Two types of filtration systems may be applied to construction stormwater treatment: rapid and slow. Rapid sand filters are the typical system used for water and wastewater treatment. They can achieve relatively high hydraulic flow rates, on the order of 2 to 20 gpm/sf, because they have automatic backwash systems to remove accumulated solids. In contrast, slow sand filters have very low hydraulic rates, on the order of 0.02 gpm/sf, because they do not have backwash systems. Slow sand filtration has generally been used to treat stormwater. Slow sand filtration is mechanically simple in comparison to rapid sand filtration but requires a much larger filter area.

**Filtration Equipment.** Sand media filters are available with automatic backwashing features that can filter to 50  $\mu\text{m}$  particle size. Screen or bag filters can filter down to 5  $\mu\text{m}$ . Fiber wound filters can remove particles down to 0.5  $\mu\text{m}$ . Filters should be sequenced from the largest to the smallest pore opening. Sediment removal efficiency will be related to particle size distribution in the stormwater.

**Treatment Process Description.** Stormwater is collected at interception point(s) on the site and is diverted to an untreated stormwater sediment pond or tank for removal of large sediment and storage of the stormwater before it is treated by the filtration system. The untreated stormwater is pumped from the trap, pond, or tank through the filtration system in a rapid sand filtration system. Slow sand filtration systems are designed as flow through systems using gravity.

***Maintenance  
Standards***

Rapid sand filters typically have automatic backwash systems that are triggered by a pre-set pressure drop across the filter. If the backwash water volume is not large or substantially more turbid than the untreated stormwater stored in the holding pond or tank, backwash return to the untreated stormwater pond or tank may be appropriate. However, other means of treatment and disposal may be necessary.

- Screen, bag, and fiber filters must be cleaned and/or replaced when they become clogged.
- Sediment shall be removed from the storage and/or treatment ponds as necessary. Typically, sediment removal is required once or twice during a wet season and at the decommissioning of the ponds.

**Sizing Criteria for Flow-Through Treatment Systems for Flow Control Exempt Water Bodies:**

When sizing storage ponds or tanks for flow-through systems for flow control exempt water bodies the treatment system capacity should be a factor. The untreated stormwater storage pond or tank should be sized to hold 1.5 times the runoff volume of the 10-year, 24-hour storm event minus the treatment system flowrate for an 8-hour period. For a chitosan-enhanced sand filtration system, the treatment system flowrate should be sized using a hydraulic loading rate between 6-8 gpm/ft<sup>2</sup>. Other hydraulic

loading rates may be more appropriate for other systems. Bypass should be provided around the chemical treatment system to accommodate extreme storms. Runoff volume shall be calculated using the methods presented in Volume 3, Chapter 2. Worst-case conditions (i.e., producing the most runoff) should be used for analyses (most likely conditions present prior to final landscaping).

### **Sizing Criteria for Flow Control Water Bodies:**

Sites that must implement flow control for the developed site condition must also control stormwater release rates during construction. Construction site stormwater discharges shall not exceed the discharge durations of the pre-developed condition for the range of pre-developed discharge rates from 1/2 of the 2-year flow through the 10-year flow as predicted by an approved continuous runoff model. The pre-developed condition to be matched shall be the land cover condition immediately prior to the development project. This restriction on release rates can affect the size of the storage pond, the filtration system, and the flow rate through the filter system.

The following is how WWHM can be used to determine the release rates from the filtration systems:

1. Determine the pre-developed flow durations to be matched by entering the land use area under the “Pre-developed” scenario in WWHM. The default flow range is from 1/2 of the 2-year flow through the 10-year flow.
2. Enter the post developed land use area in the “Developed Unmitigated” scenario in WWHM.
3. Copy the land use information from the “Developed Unmitigated” to “Developed Mitigated” scenario.
4. There are two possible ways to model stormwater filtration systems:
  - a. The stormwater filtration system uses an untreated stormwater storage pond/tank and the discharge from this pond/tank is pumped to one or more filters. In-line filtration chemicals would be added to the flow right after the pond/tank and before the filter(s). Because the discharge is pumped, WWHM can't generate a stage/storage /discharge (SSD) table for this system. This system is modeled the same way as described in [BMP C250](#) and is as follows:

While in the “Developed Mitigated” scenario, add a pond element under the basin element containing the post-developed land use areas. This pond element represents information on the available untreated stormwater storage and discharge from the filtration system. In cases where the discharge from the filtration system is controlled by a pump, a stage/storage/discharge (SSD) table representing the pond must be generated outside WWHM and

imported into WWHM. WWHM can route the runoff from the post-developed condition through this SSD table (the pond) and determine compliance with the flow duration standard. This would be an iterative design procedure where if the initial SSD table proved to be out of compliance, the designer would have to modify the SSD table outside WWHM and re-import in WWHM and route the runoff through it again. The iteration will continue until a pond that enables compliance with the flow duration standard is designed.

Notes on SSD table characteristics:

- The pump discharge rate would likely be initially set at just below  $\frac{1}{2}$  of the 2-year flow from the pre-developed condition. As runoff coming into the untreated stormwater storage pond increases and the available untreated stormwater storage volume gets used up, it would be necessary to increase the pump discharge rate above  $\frac{1}{2}$  of the 2-year. The increase(s) above  $\frac{1}{2}$  of the 2-year must be such that they provide some relief to the untreated stormwater storage needs but at the same time they will not cause violations of the flow duration standard at the higher flows. The final design SSD table will identify the appropriate pumping rates and the corresponding stage and storages.
  - When building such a flow control system, the design must ensure that any automatic adjustments to the pumping rates will be as a result of changes to the available storage in accordance with the final design SSD table.
- b. The stormwater filtration system uses a storage pond/tank and the discharge from this pond/tank gravity flows to the filter. This is usually a slow sand filter system and it is possible to model it in WWHM as a Filter element or as a combination of Pond and Filter element placed in series. The stage/storage/discharge table(s) may then be generated within WWHM as follows:
- (i) While in the “Developed Mitigated” scenario, add a Filter element under the basin element containing the post-developed land use areas. The length and width of this filter element would have to be the same as the bottom length and width of the upstream untreated stormwater storage pond/tank.
  - (ii) In cases where the length and width of the filter is not the same as those for the bottom of the upstream untreated stormwater storage tank/pond, the treatment system may be modeled as a Pond element followed by a Filter element. By having these two elements, WWHM would then generate a SSD table for the storage pond which then gravity flows to the Filter element. The Filter element downstream of the untreated stormwater

storage pond would have a storage component through the media, and an overflow component for when the filtration capacity is exceeded.

WWHM can route the runoff from the post-developed condition through the treatment systems in 4b and determine compliance with the flow duration standard. This would be an iterative design procedure where if the initial sizing estimates for the treatment system proved to be inadequate, the designer would have to modify the system and route the runoff through it again. The iteration would continue until compliance with the flow duration standard is achieved.

5. It should be noted that the above procedures would be used to meet the flow control requirements. The filtration system must be able to meet the runoff treatment requirements. It is likely that the discharge flow rate of  $\frac{1}{2}$  of the 2-year or more may exceed the treatment capacity of the system. If that is the case, the untreated stormwater discharge rate(s) (i.e., influent to the treatment system) must be reduced to allow proper treatment. Any reduction in the flows would likely result in the need for a larger untreated stormwater storage volume.

If system design does not allow you to discharge at the slower rates as described above and if the site has a retention or detention pond that will serve the planned development, the discharge from the treatment system may be directed to the permanent retention/detention pond to comply with the flow control requirements. In this case, the untreated stormwater storage pond and treatment system will be sized according to the sizing criteria for flow-through treatment systems for flow control exempt waterbodies described earlier except all discharges (water passing through the treatment system and stormwater bypassing the treatment system) will be directed into the permanent retention/detention pond. If site constraints make locating the untreated stormwater storage pond difficult, the permanent retention/detention pond may be divided to serve as the untreated stormwater discharge pond and the post-treatment flow control pond. A berm or barrier must be used in this case so the untreated water does not mix with the treated water. Both untreated stormwater storage requirements, and adequate post-treatment flow control must be achieved. The post-treatment flow control pond's revised dimensions must be entered into the WWHM and the WWHM must be run to confirm compliance with the flow control requirement.

## **BMP C252: High pH Neutralization Using CO<sub>2</sub>**

### ***Purpose***

When pH levels in stormwater rise above 8.5 it is necessary to lower the pH levels to the acceptable range of 6.5 to 8.5, this process is called pH neutralization. pH neutralization involves the use of solid or compressed carbon dioxide gas in water requiring neutralization. Neutralized stormwater may be discharged to surface waters under the General Construction NPDES permit.

Neutralized process water such as concrete truck wash-out, hydro-demolition, or saw-cutting slurry must be managed to prevent discharge to surface waters. Any stormwater contaminated during concrete work is considered process wastewater and must not be discharged to surface waters.

### **Reason for pH Neutralization:**

A pH level range of 6.5 to 8.5 is typical for most natural watercourses, and this neutral pH is required for the survival of aquatic organisms. Should the pH rise or drop out of this range, fish and other aquatic organisms may become stressed and may die.

Calcium hardness can contribute to high pH values and cause toxicity that is associated with high pH conditions. A high level of calcium hardness in waters of the state is not allowed.

The water quality standard for pH in Washington State is in the range of 6.5 to 8.5. Ground water standard for calcium and other dissolved solids in Washington State is less than 500 mg/l.

### ***Conditions of Use***

#### **Causes of High pH:**

High pH at construction sites is most commonly caused by the contact of stormwater with poured or recycled concrete, cement, mortars, and other Portland cement or lime containing construction materials. (See [BMP C151: Concrete Handling](#) for more information on concrete handling procedures). The principal caustic agent in cement is calcium hydroxide (free lime).

#### **Advantages of CO<sub>2</sub> Sparging:**

- Rapidly neutralizes high pH water.
- Cost effective and safer to handle than acid compounds.
- CO<sub>2</sub> is self-buffering. It is difficult to overdose and create harmfully low pH levels.
- Material is readily available.

***Design and  
Installation  
Specifications***

**The Chemical Process:**

When carbon dioxide (CO<sub>2</sub>) is added to water (H<sub>2</sub>O), carbonic acid (H<sub>2</sub>CO<sub>3</sub>) is formed which can further dissociate into a proton (H<sup>+</sup>) and a bicarbonate anion (HCO<sub>3</sub><sup>-</sup>) as shown below:



The free proton is a weak acid that can lower the pH. Water temperature has an effect on the reaction as well. The colder the water temperature is the slower the reaction occurs and the warmer the water temperature is the quicker the reaction occurs. Most construction applications in Washington State have water temperatures in the 50°F or higher range so the reaction is almost simultaneous.

**Treatment Process:**

High pH water may be treated using continuous treatment, continuous discharge systems. These manufactured systems continuously monitor influent and effluent pH to ensure that pH values are within an acceptable range before being discharged. All systems must have fail safe automatic shut off switches in the event that pH is not within the acceptable discharge range. Only trained operators may operate manufactured systems. System manufacturers often provide trained operators or training on their devices.

The following procedure may be used when not using a continuous discharge system:

1. Prior to treatment, the appropriate jurisdiction should be notified in accordance with the regulations set by the jurisdiction.
2. Every effort should be made to isolate the potential high pH water in order to treat it separately from other stormwater on-site.
3. Water should be stored in an acceptable storage facility, detention pond, or containment cell prior to treatment.
4. Transfer water to be treated to the treatment structure. Ensure that treatment structure size is sufficient to hold the amount of water that is to be treated. Do not fill tank completely, allow at least 2 feet of freeboard.
5. The operator samples the water for pH and notes the clarity of the water. As a rule of thumb, less CO<sub>2</sub> is necessary for clearer water. This information should be recorded.
6. In the pH adjustment structure, add CO<sub>2</sub> until the pH falls in the range of 6.9-7.1. Remember that pH water quality standards apply so adjusting pH to within 0.2 pH units of receiving water (background pH) is recommended. It is unlikely that pH can be adjusted to within 0.2 pH units using dry ice. Compressed carbon dioxide gas should be introduced to the water using a carbon dioxide diffuser located near



the bottom of the tank, this will allow carbon dioxide to bubble up through the water and diffuse more evenly.

7. Slowly discharge the water making sure water does not get stirred up in the process. Release about 80% of the water from the structure leaving any sludge behind.
8. Discharge treated water through a pond or drainage system.
9. Excess sludge needs to be disposed of properly as concrete waste. If several batches of water are undergoing pH treatment, sludge can be left in treatment structure for the next batch treatment. Dispose of sludge when it fills 50% of tank volume.

Sites that must implement flow control for the developed site must also control stormwater release rates during construction. All treated stormwater must go through a flow control facility before being released to surface waters which require flow control.

### ***Maintenance Standards***

#### **Safety and Materials Handling:**

- All equipment should be handled in accordance with OSHA rules and regulations.
- Follow manufacturer guidelines for materials handling.

#### **Operator Records:**

Each operator should provide:

- A diagram of the monitoring and treatment equipment.
- A description of the pumping rates and capacity the treatment equipment is capable of treating.

Each operator should keep a written record of the following:

- Client name and phone number.
- Date of treatment.
- Weather conditions.
- Project name and location.
- Volume of water treated.
- pH of untreated water.
- Amount of CO<sub>2</sub> needed to adjust water to a pH range of 6.9-7.1.
- pH of treated water.
- Discharge point location and description.

A copy of this record should be given to the client/contractor who should retain the record for three years.

## **BMP C253: pH Control for High pH Water**

### ***Purpose***

When pH levels in stormwater rise above 8.5 it is necessary to lower the pH levels to the acceptable range of 6.5 to 8.5, this process is called pH neutralization. Stormwater with pH levels exceeding water quality standards may be treated by infiltration, dispersion in vegetation or compost, pumping to a sanitary sewer, disposal at a permitted concrete batch plant with pH neutralization capabilities, or carbon dioxide sparging. [BMP C252](#) gives guidelines for carbon dioxide sparging.

### **Reason for pH Neutralization:**

A pH level range of 6.5 to 8.5 is typical for most natural watercourses, and this pH range is required for the survival of aquatic organisms. Should the pH rise or drop out of this range, fish and other aquatic organisms may become stressed and may die.

### ***Conditions of Use***

#### **Causes of High pH:**

High pH levels at construction sites are most commonly caused by the contact of stormwater with poured or recycled concrete, cement, mortars, and other Portland cement or lime containing construction materials. (See [BMP C151: Concrete Handling](#) for more information on concrete handling procedures). The principal caustic agent in cement is calcium hydroxide (free lime).

### ***Design and Installation Specifications***

#### **Disposal Methods:**

##### **Infiltration**

- Infiltration is only allowed if soil type allows all water to infiltrate (no surface runoff) without causing or contributing to a violation of surface or ground water quality standards.
- Infiltration techniques should be consistent with Volume V, Chapter 7

##### **Dispersion**

Use BMP T5.30 Full Dispersion

##### **Sanitary Sewer Disposal**

- Local sewer authority approval is required prior to disposal via the sanitary sewer.

##### **Concrete Batch Plant Disposal**

- Only permitted facilities may accept high pH water.
- Facility should be contacted before treatment to ensure they can accept the high pH water.

##### **Stormwater Discharge**

Any pH treatment options that generate treated water that must be discharged off site are subject to flow control requirements. Sites that must implement flow control for the developed site must also control

stormwater release rates during construction. All treated stormwater must go through a flow control facility before being released to surface waters which require flow control.